

N704P277398D

N704P277399D

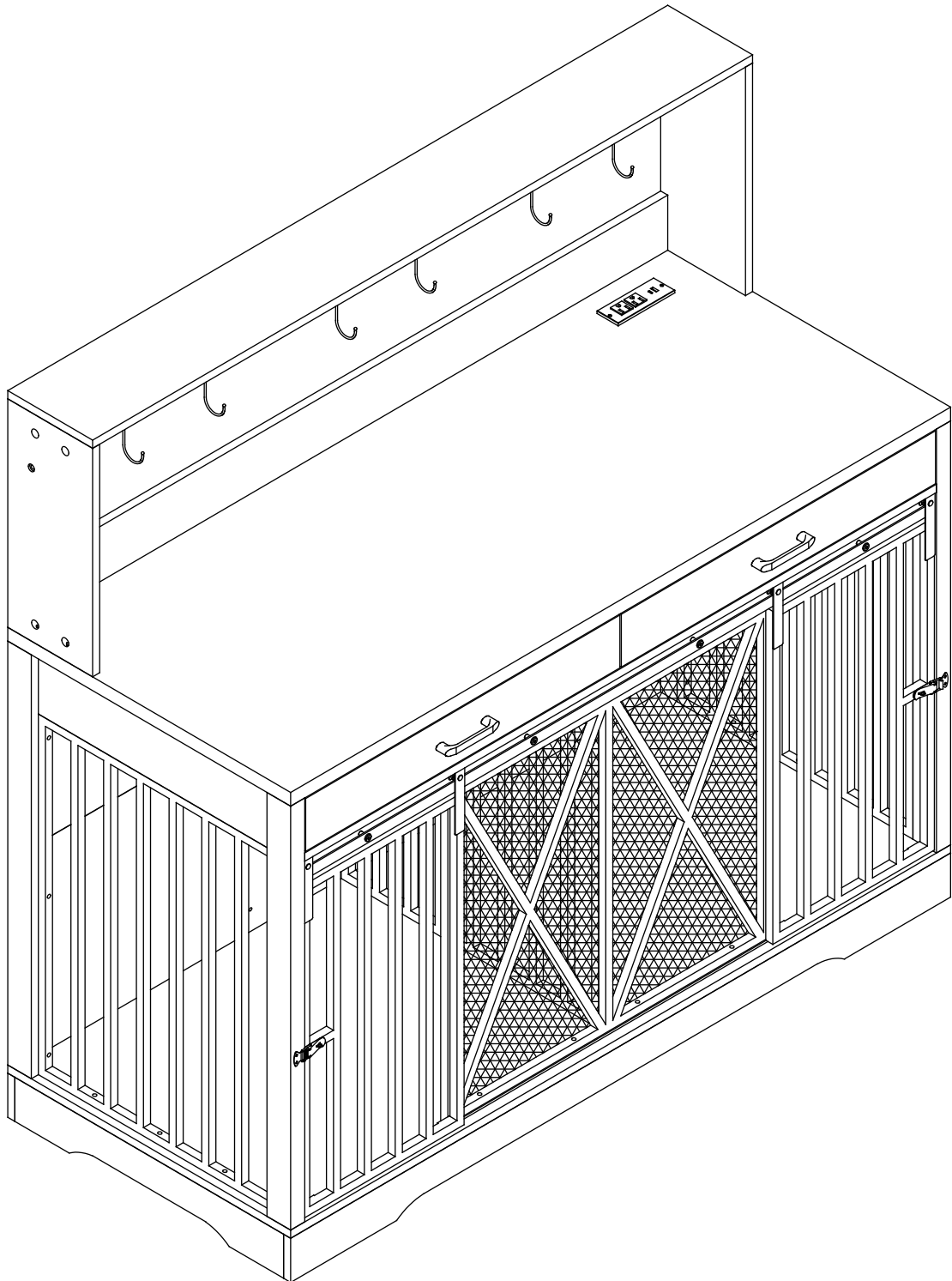

2PERS

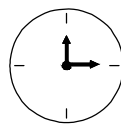

45 MIN

Tool Required Not Provided

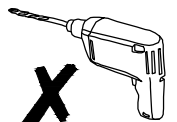
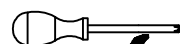
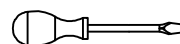



[EN]

Warning: Please read these instructions fully before starting assembly. Check you have all the components and tools listed on pages. Keep the instructions for later reference. Parts of the assembly will be easier with 2 people. Seek professional assistance if necessary.

Warning: Please place all parts on a flat surface. Place a soft blanket or similar underneath to protect against scratches or stains. Avoid dragging or sliding components across the floor.

Warning: Regularly check all fittings and fastenings to ensure they are secure and to prevent accidents. If any parts are missing, broken, damaged, or worn, discontinue use of the product until repairs have been made using factory authorized parts.

Warning: Do not allow children to climb on the furniture as this may result in tipping and serious personal injury. Assemble the furniture away from the reach of children.



Warning: Do not place furniture close to fire sources or high-temperature objects to avoid the risk of fire. Do not place furniture in damp environments to prevent material damage.

Warning: Clean furniture with a damp cloth or alcohol, avoid using cleaning agents containing corrosive chemicals.

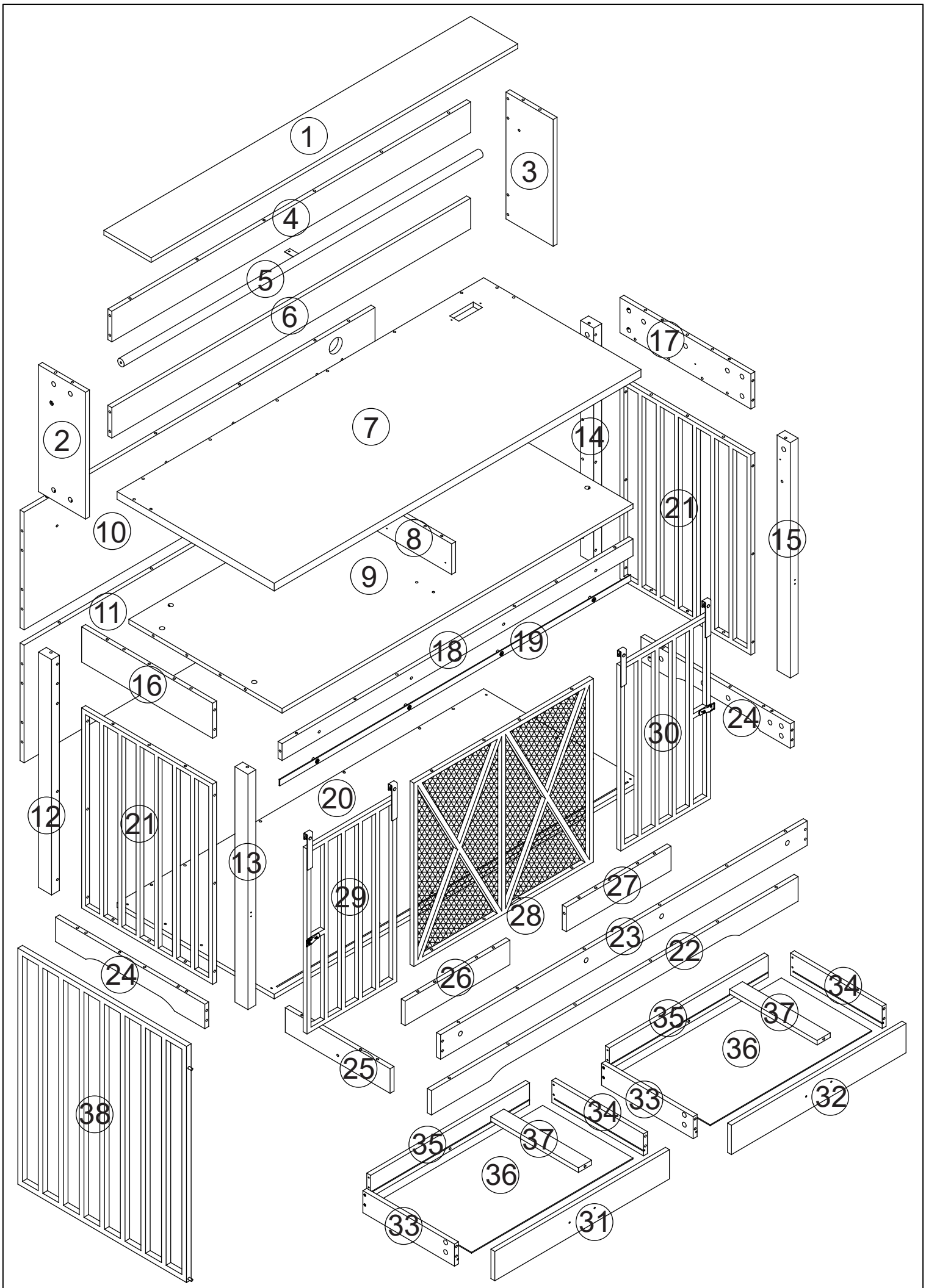
Warning: This product is equipped with an anti-tilt device. Please be sure to install this device to prevent unnecessary injuries caused by tipping.

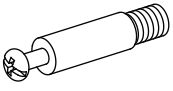
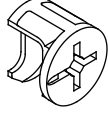
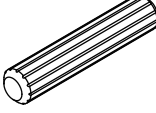
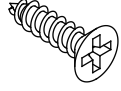
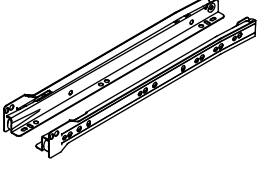
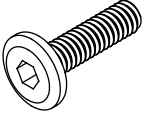
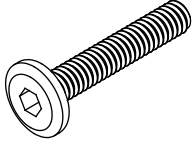
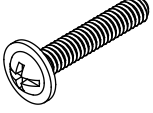
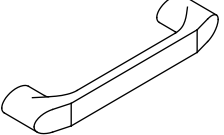
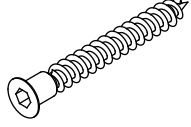
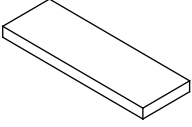
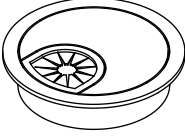
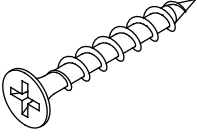

Hardwareliste

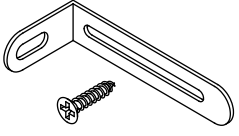
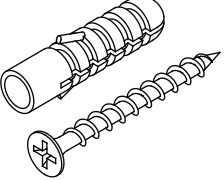
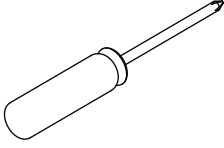
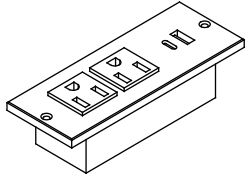
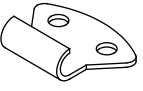
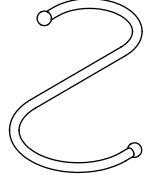
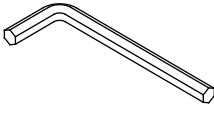
<p>A x 120+2</p>  <p>7x40mm</p>	<p>B x 120+2</p>  <p>15x10mm</p>	<p>C x 50+2</p> 	<p>D x 23+2</p> 	<p>E x 2</p> 
<p>F x 24+1</p> 	<p>G x 6</p> 	<p>H x 4</p> 	<p>I x 2</p> 	<p>J x 14+1</p> 
<p>K x 4</p> 	<p>L x 1</p> 	<p>M x 8+1</p> 	<p>N x 120+2</p> 	<p>O x 2</p> 
<p>P x 2</p> 	<p>Q x 1</p> 	<p>R x 1</p> 	<p>S x 2</p> 	<p>T x 6</p> 
<p>U x 1</p> 				

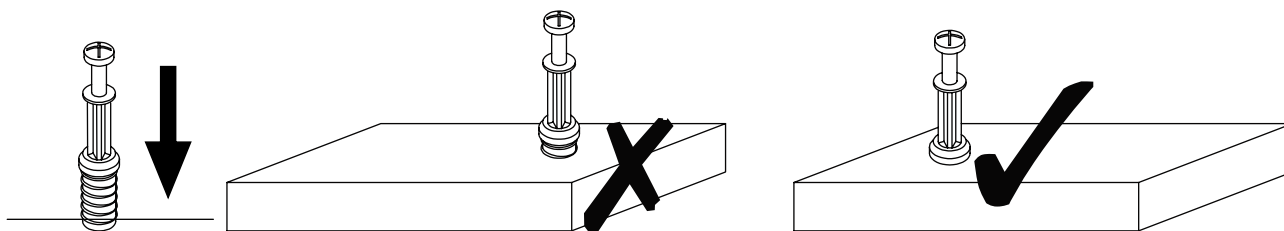

EN_QUICKFIT: Tighten quickfit until shoulder is flush with panel. Do not overtighten or undertighten.

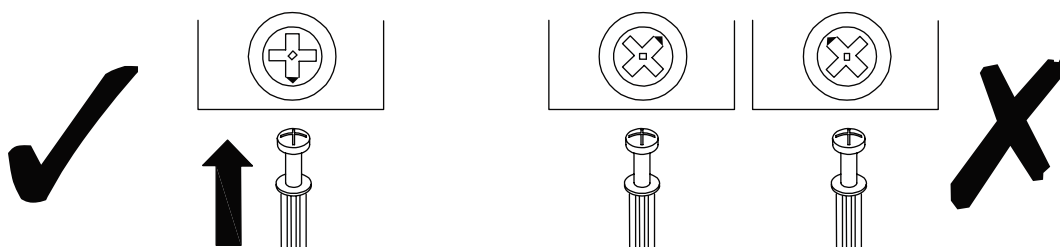

EN_CAM LOCK: When fitting cam lock, ensure starting position is correct before you insert connecting quickfit.

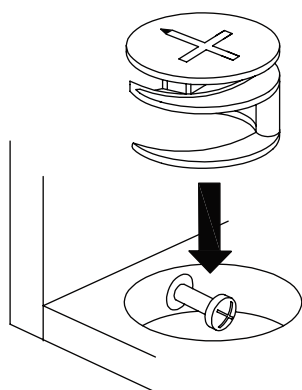

EN_Quickfit head should be in the centre of the cam lock when the two panels are joined.
Cam lock should be inserted before quickfit.

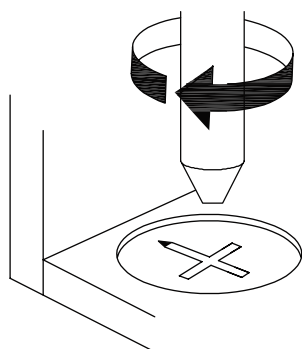



EN_Turn cam lock clockwise to tighten.

Before installation, insert the screws into the holes and tighten them, but do not tighten them to 100%, 70% to 80% is sufficient. Finally, after all screws are installed, tighten all screws to 100%.

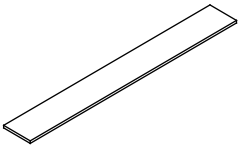
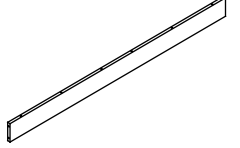
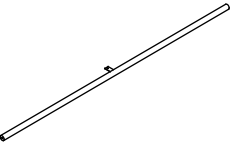
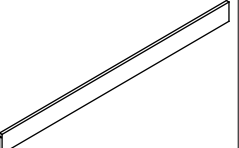
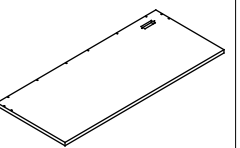
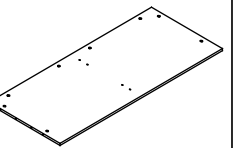
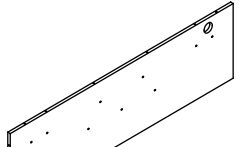
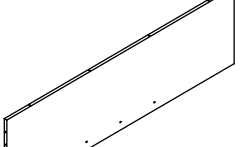
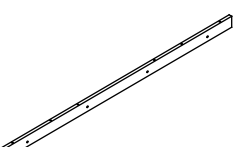
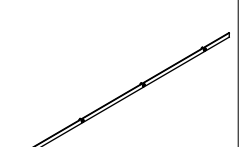
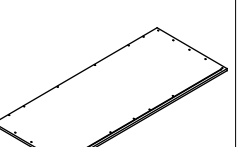
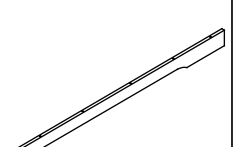
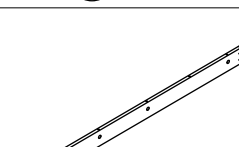
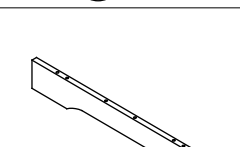
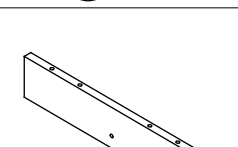
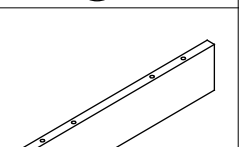
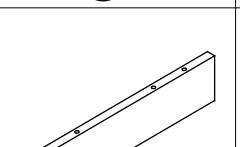
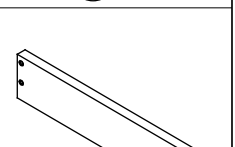
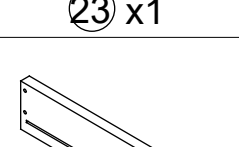
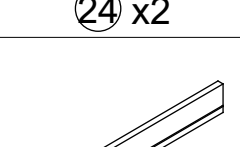
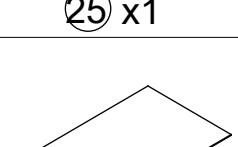
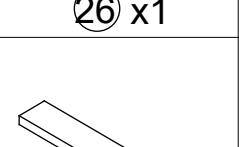
N704P277398D

 ① x1	 ④ x1	 ⑤ x1	 ⑥ x1	 ⑦ x1	 ⑨ x1
 ⑩ x1	 ⑪ x1	 ⑱ x1	 ⑲ x1	 ⑳ x1	 ㉒ x1
 ㉓ x1	 ㉔ x2	 ㉕ x1	 ㉖ x1	 ㉗ x1	 ㉓ x2
 ㉔ x2	 ㉕ x2	 ㉖ x2	 ㉗ x2		

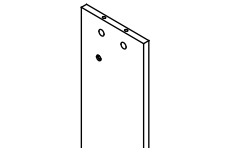
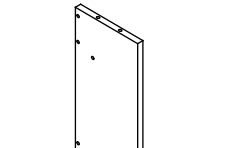
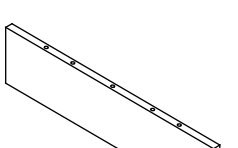
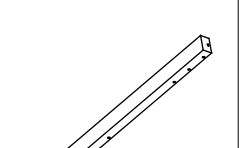
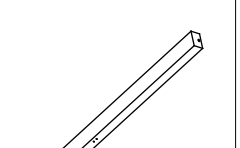
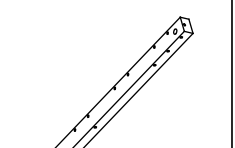
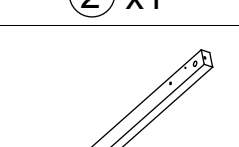
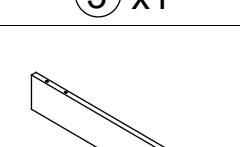
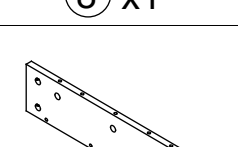
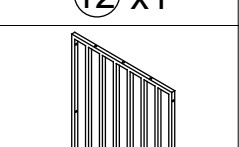
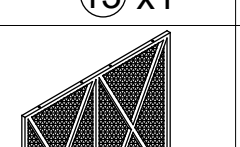
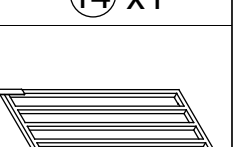
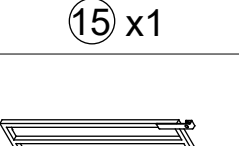
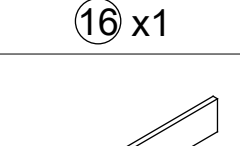
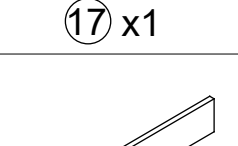
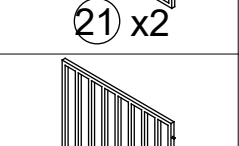
N704P277399D

 ② x1	 ③ x1	 ⑧ x1	 ⑫ x1	 ⑬ x1	 ⑭ x1
 ⑮ x1	 ⑯ x1	 ⑰ x1	 ㉑ x2	 ㉘ x1	 ㉙ x1
 ⑳ x1	 ㉑ x1	 ㉒ x1	 ㉘ x1	 Hardware	

1

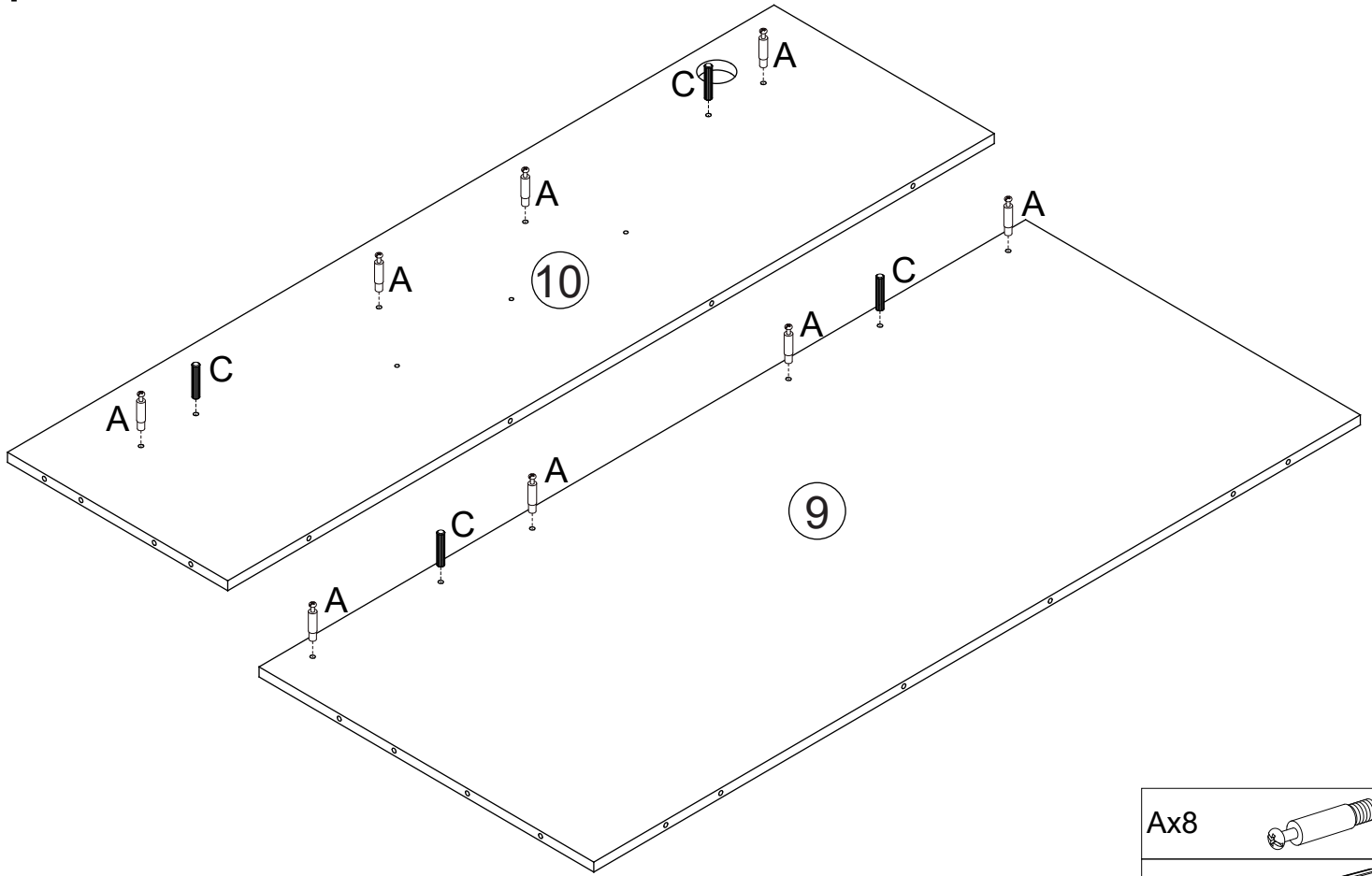

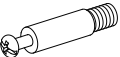
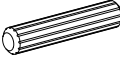
- Ax8 
- Cx4 

2

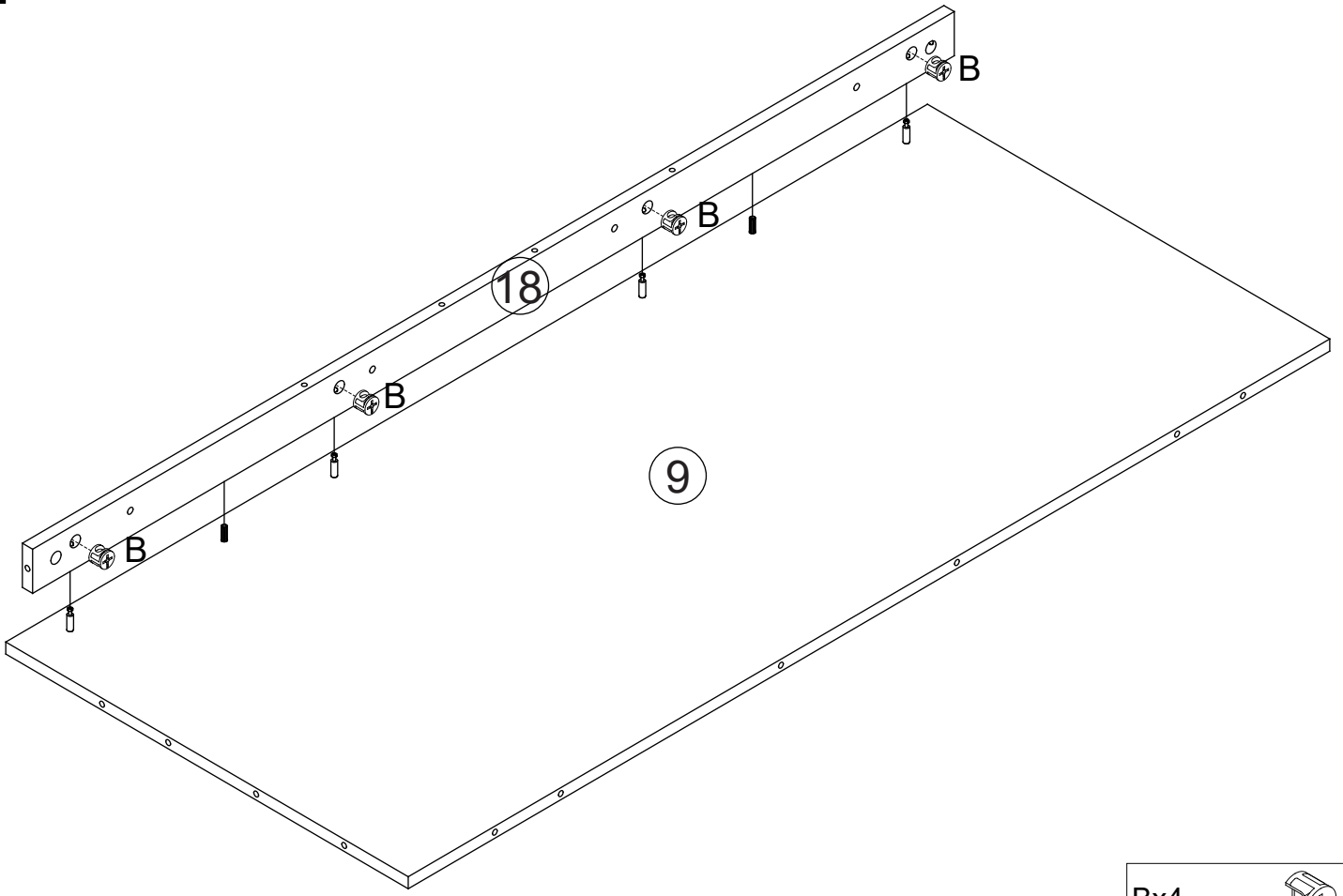

- Bx4 

3

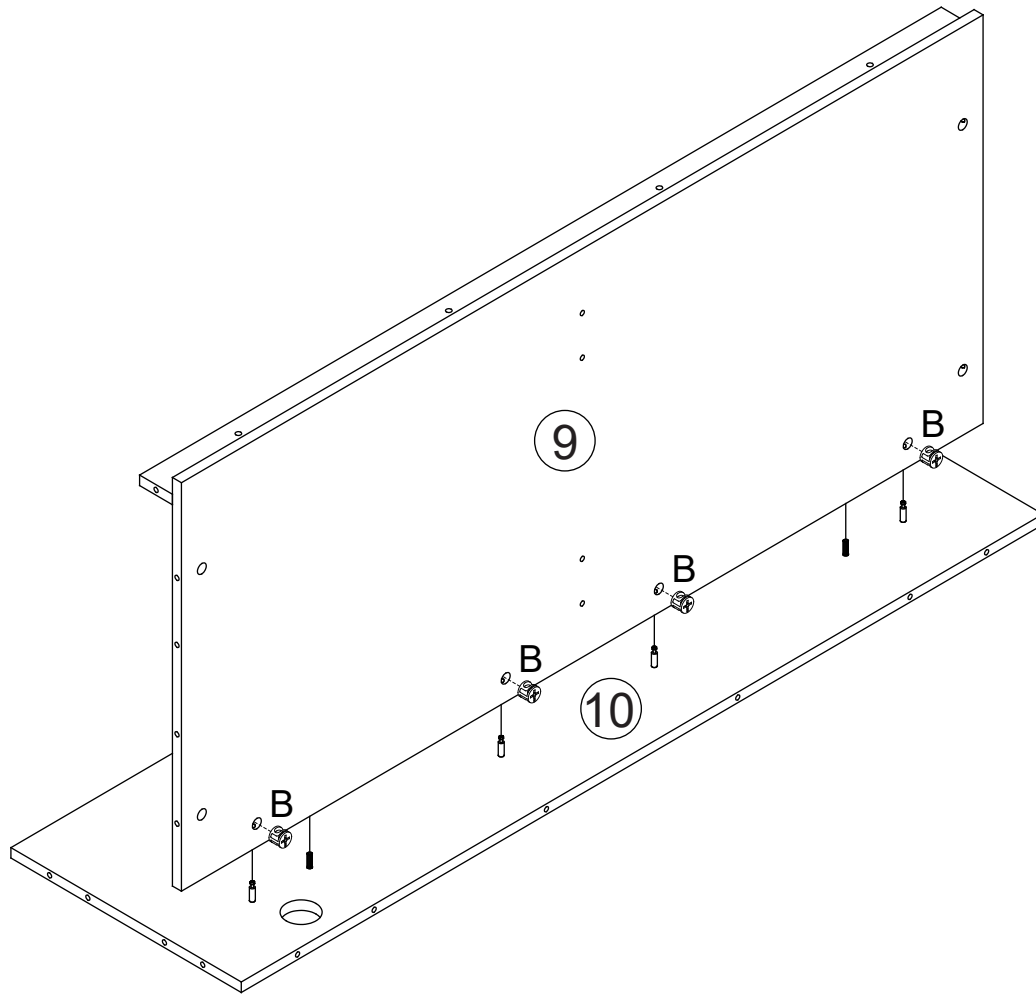

Bx4



4

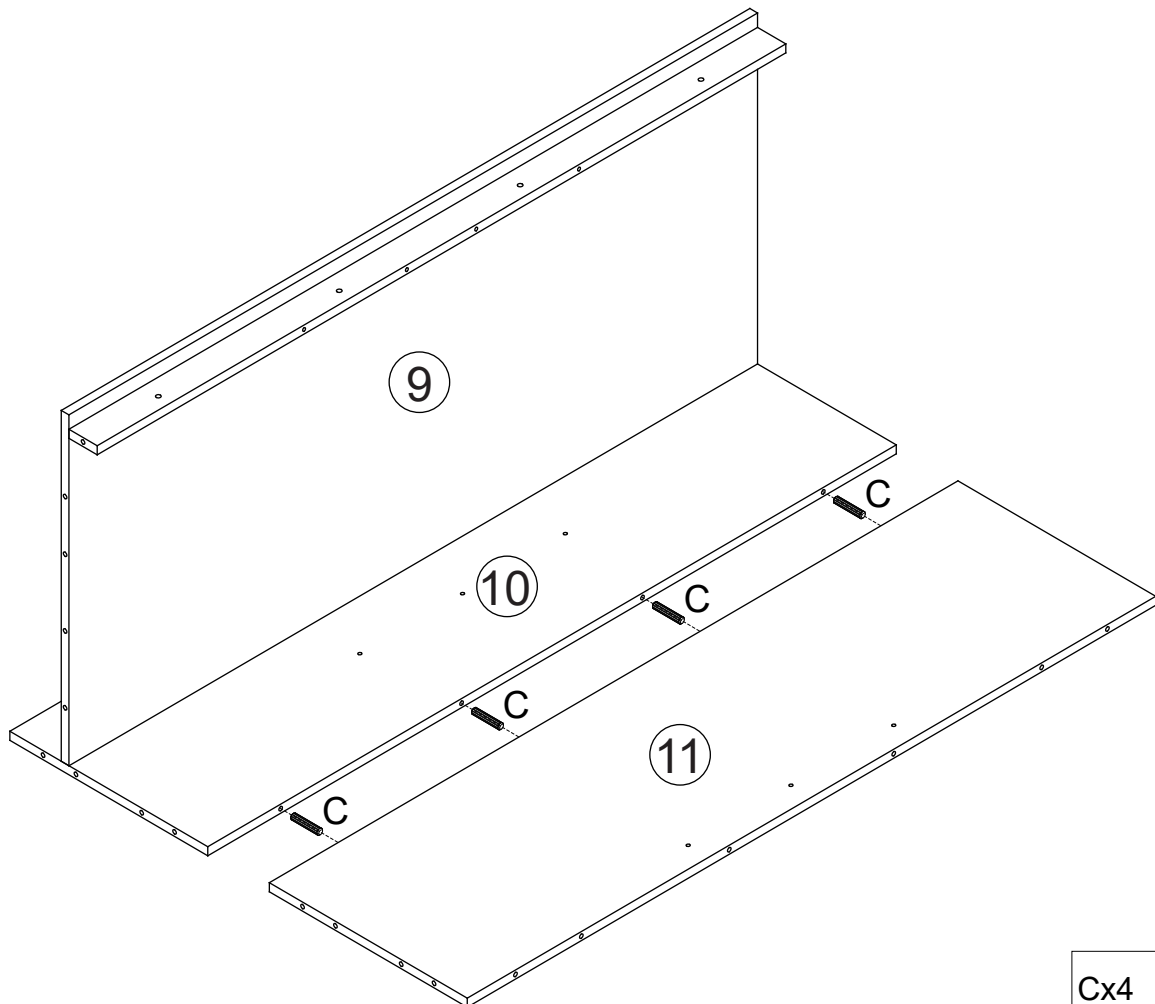



Cx4

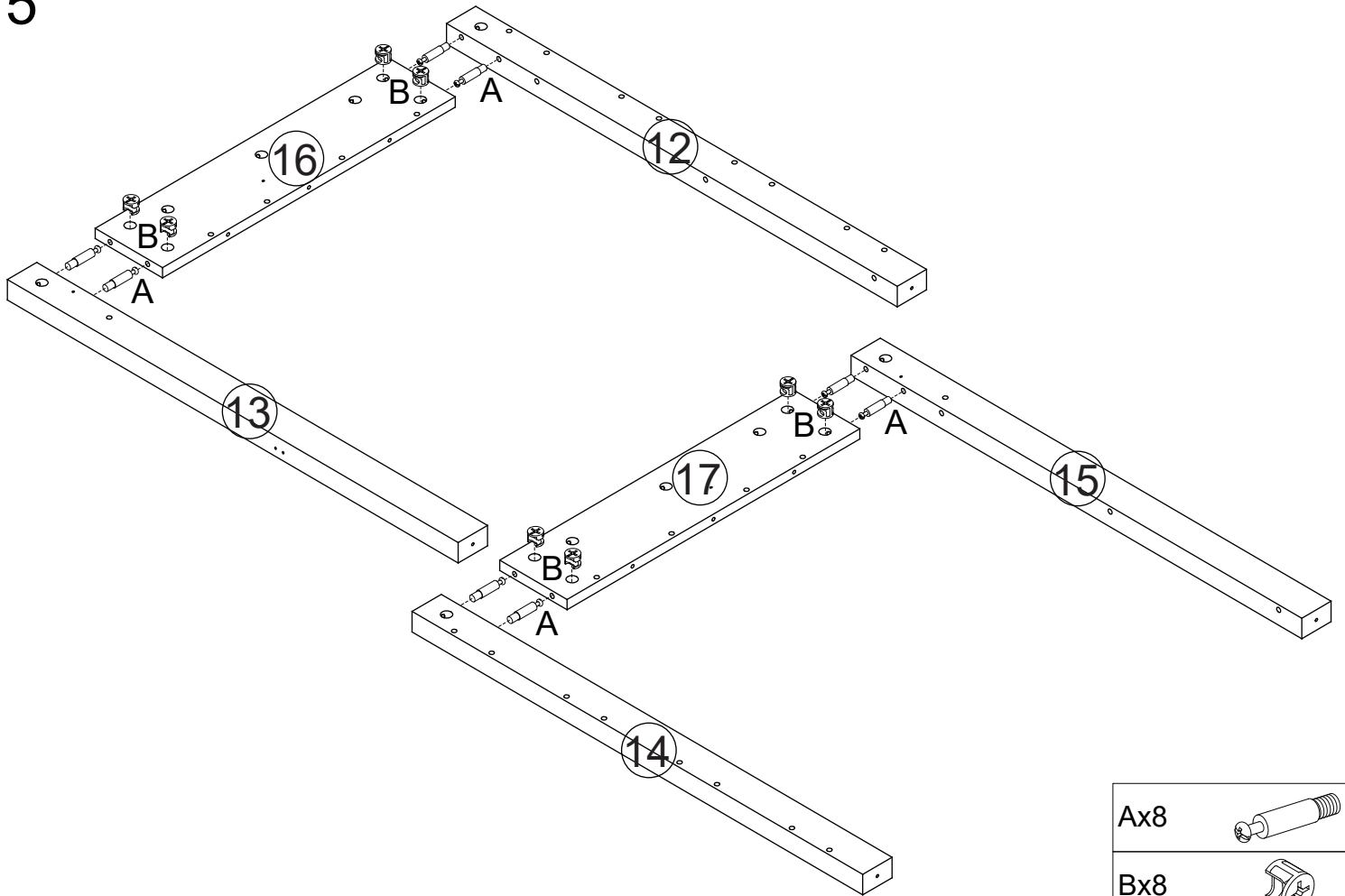

5

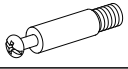

Ax8	
Bx8	

6

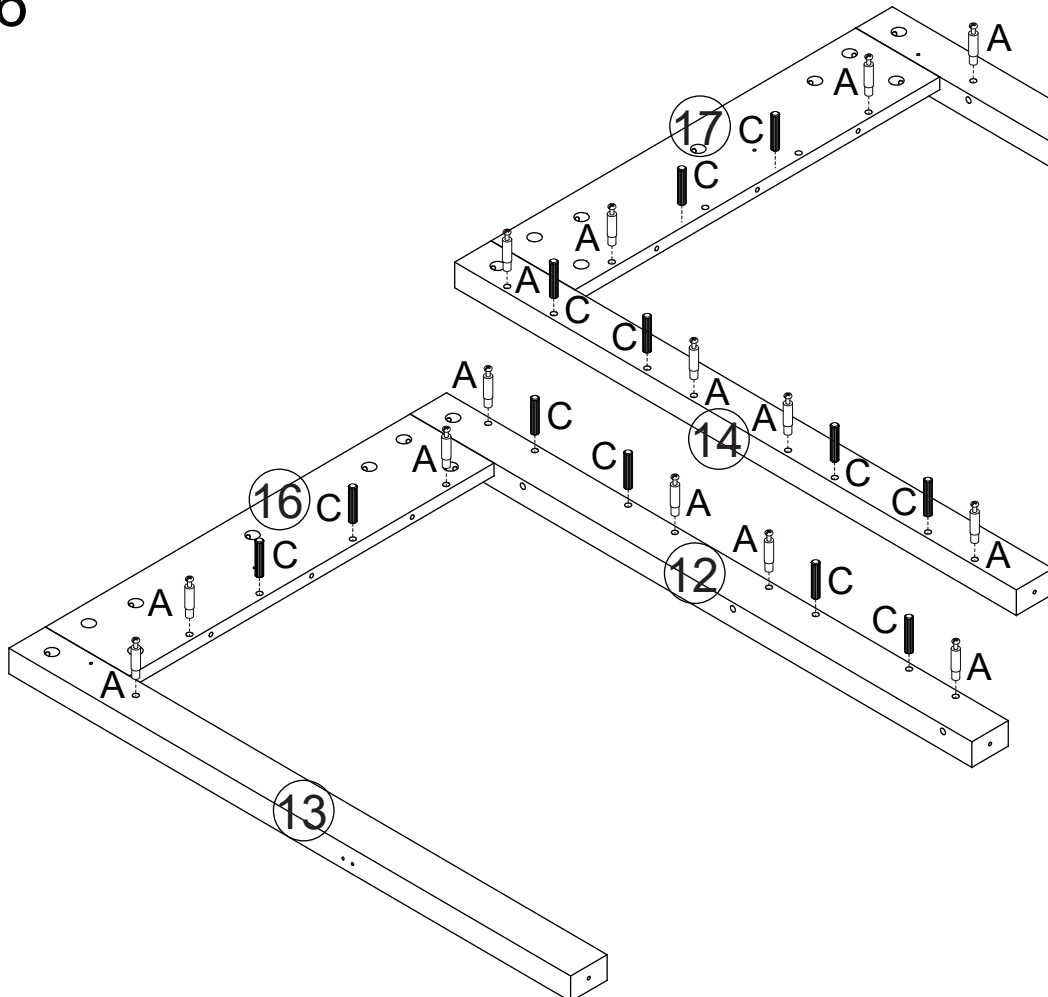

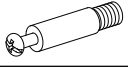
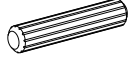

Ax14	
Cx12	

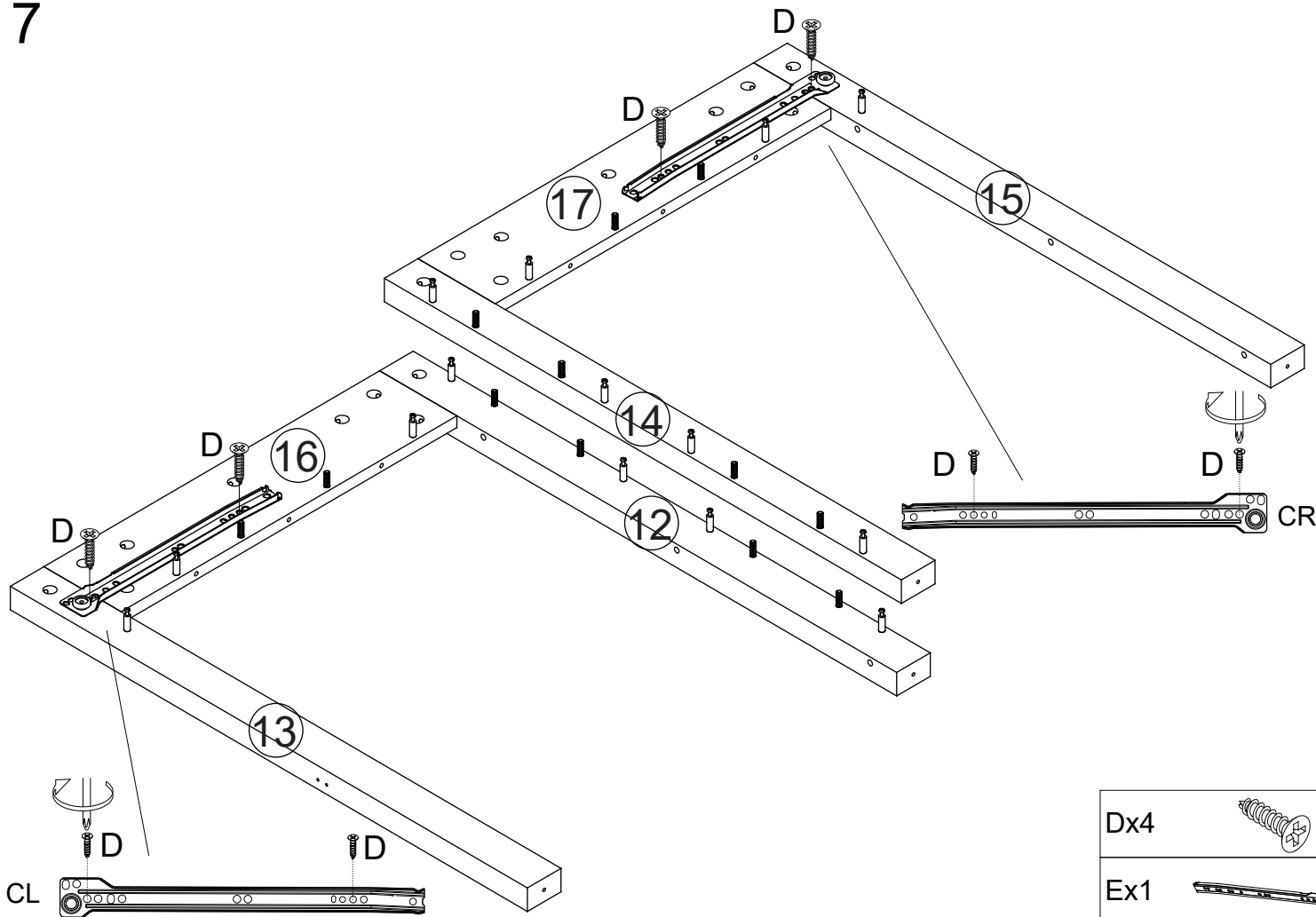
7

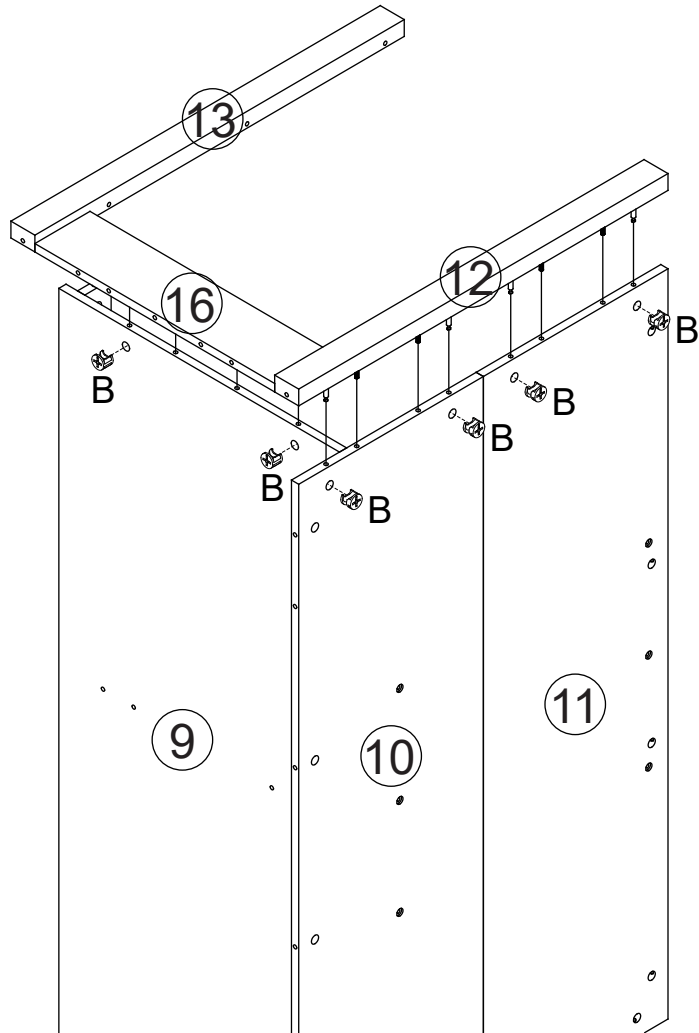

8



Dx4	
Ex1	

Bx7	
-----	---

9

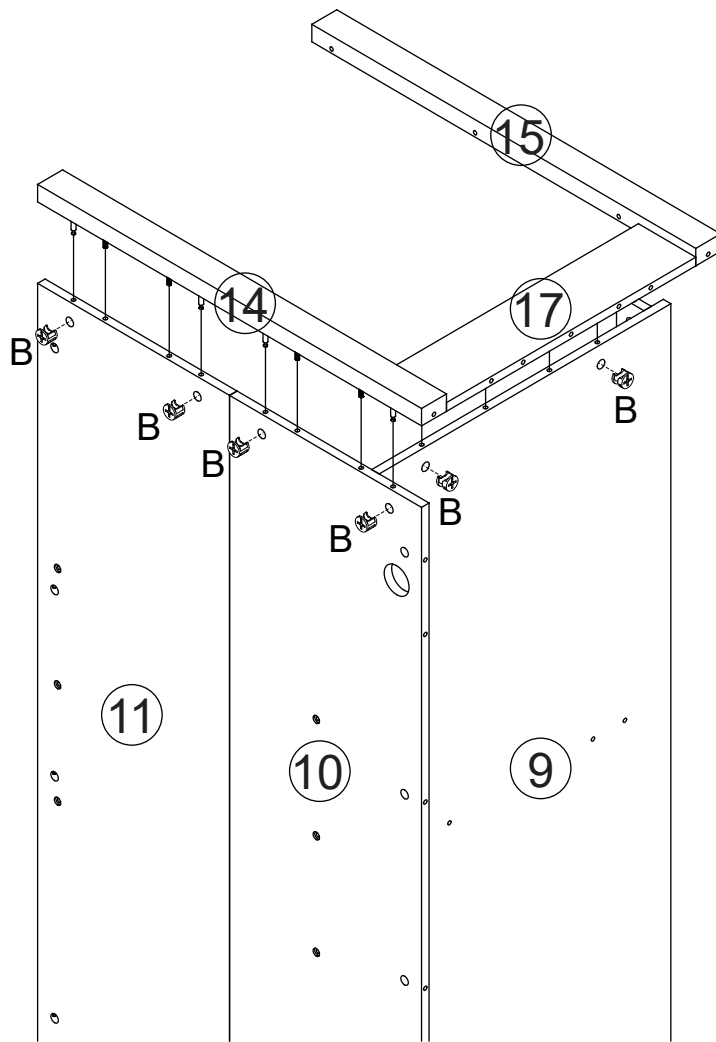

Bx7



10

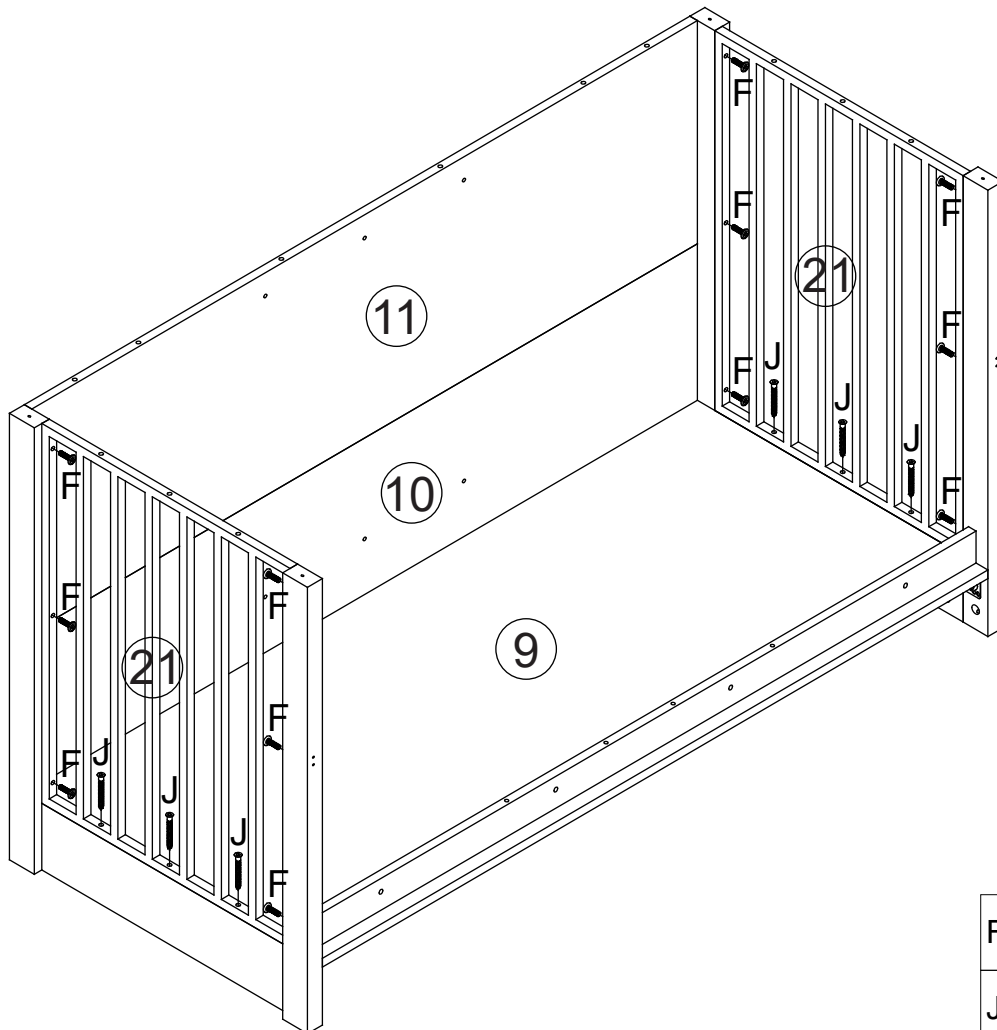

Fx12

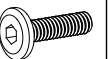

Jx6



11

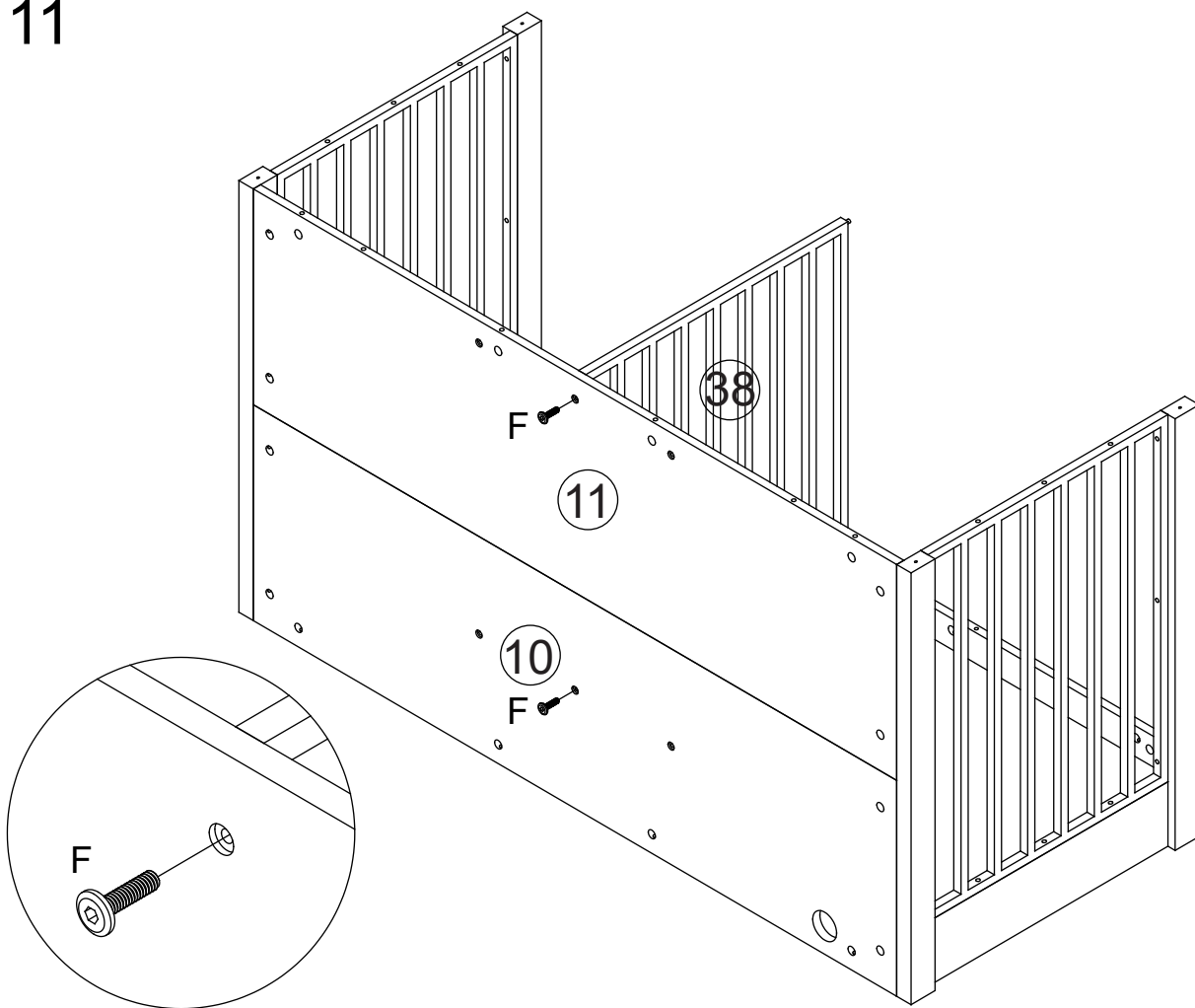

Fx2

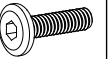

12

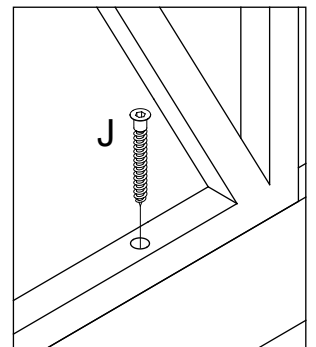
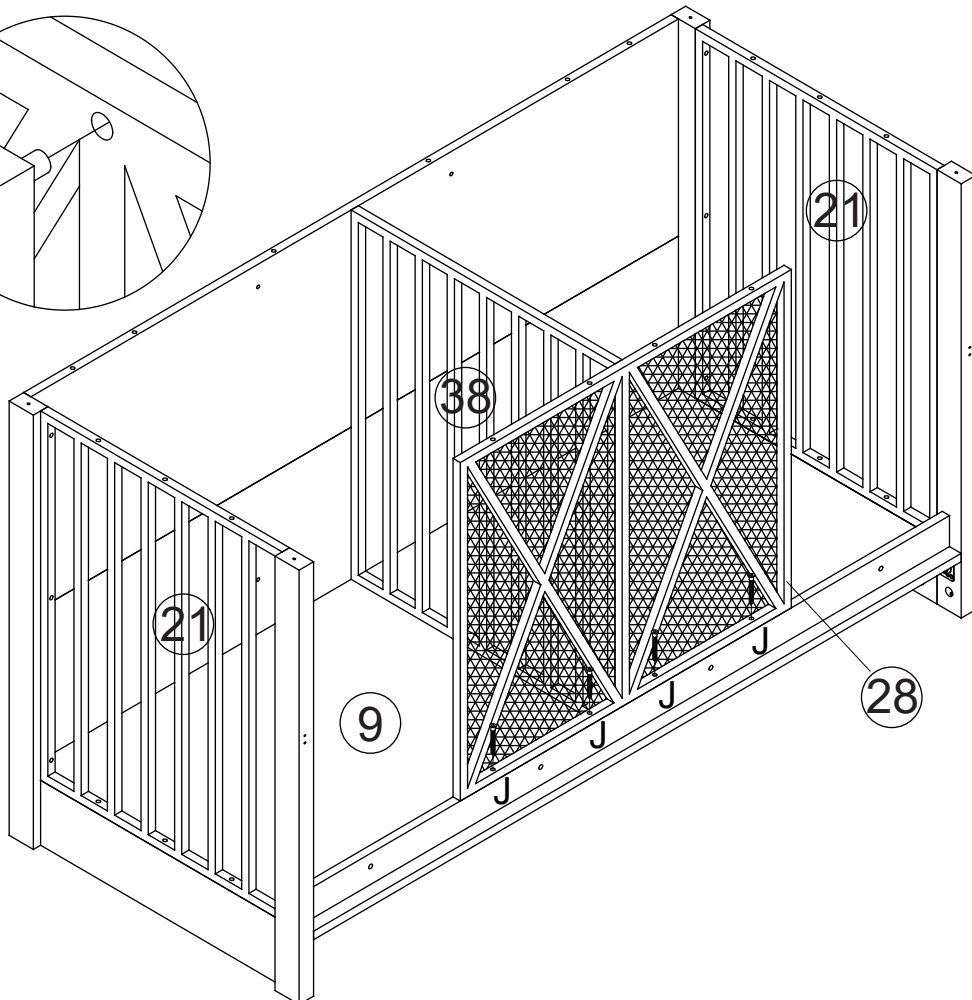
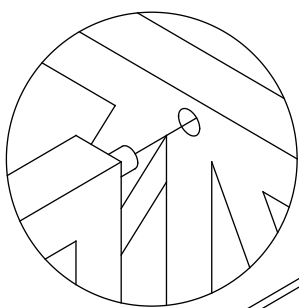

Jx4



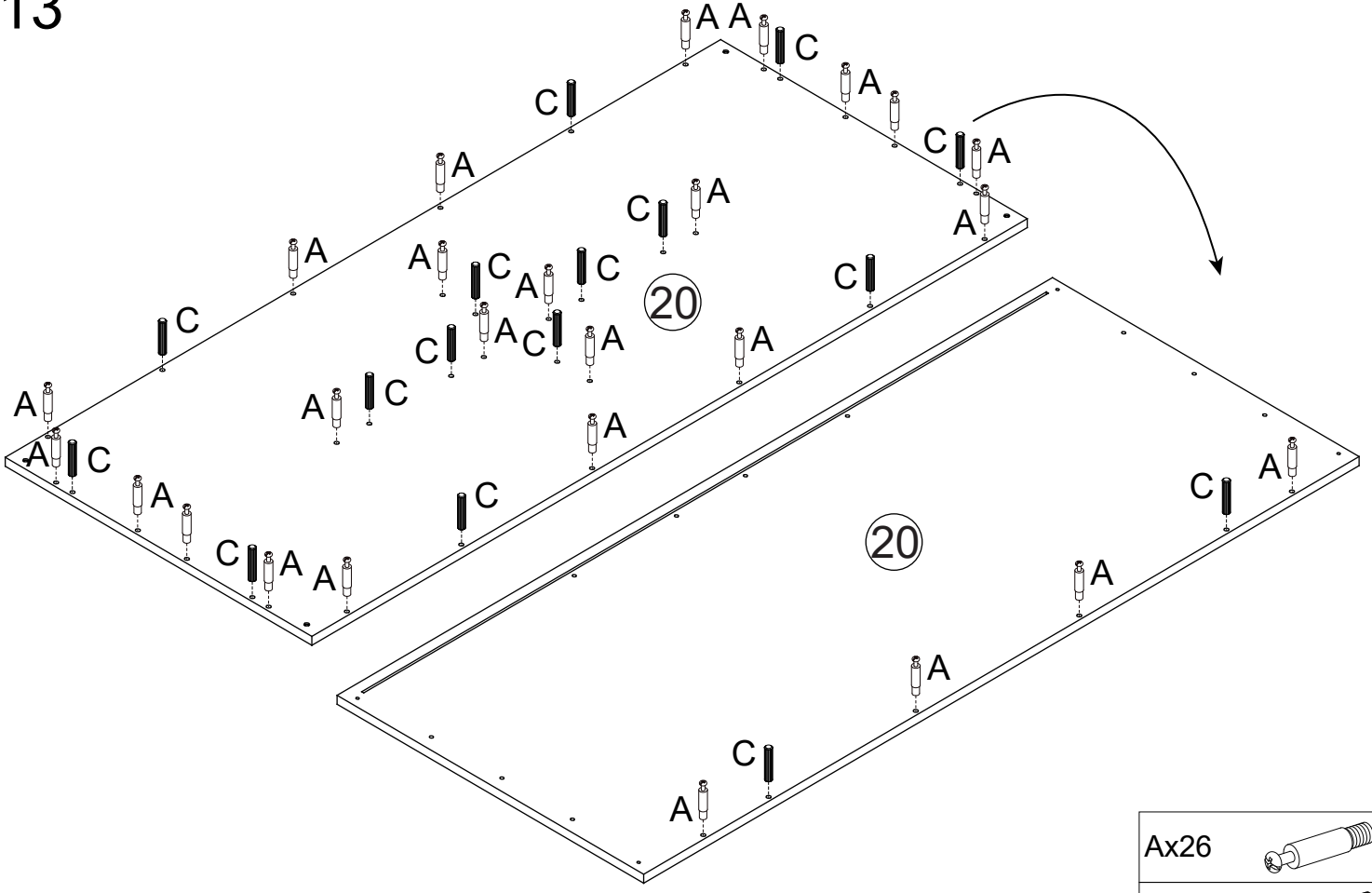

13

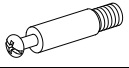
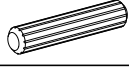

- Ax26 
- Cx16 

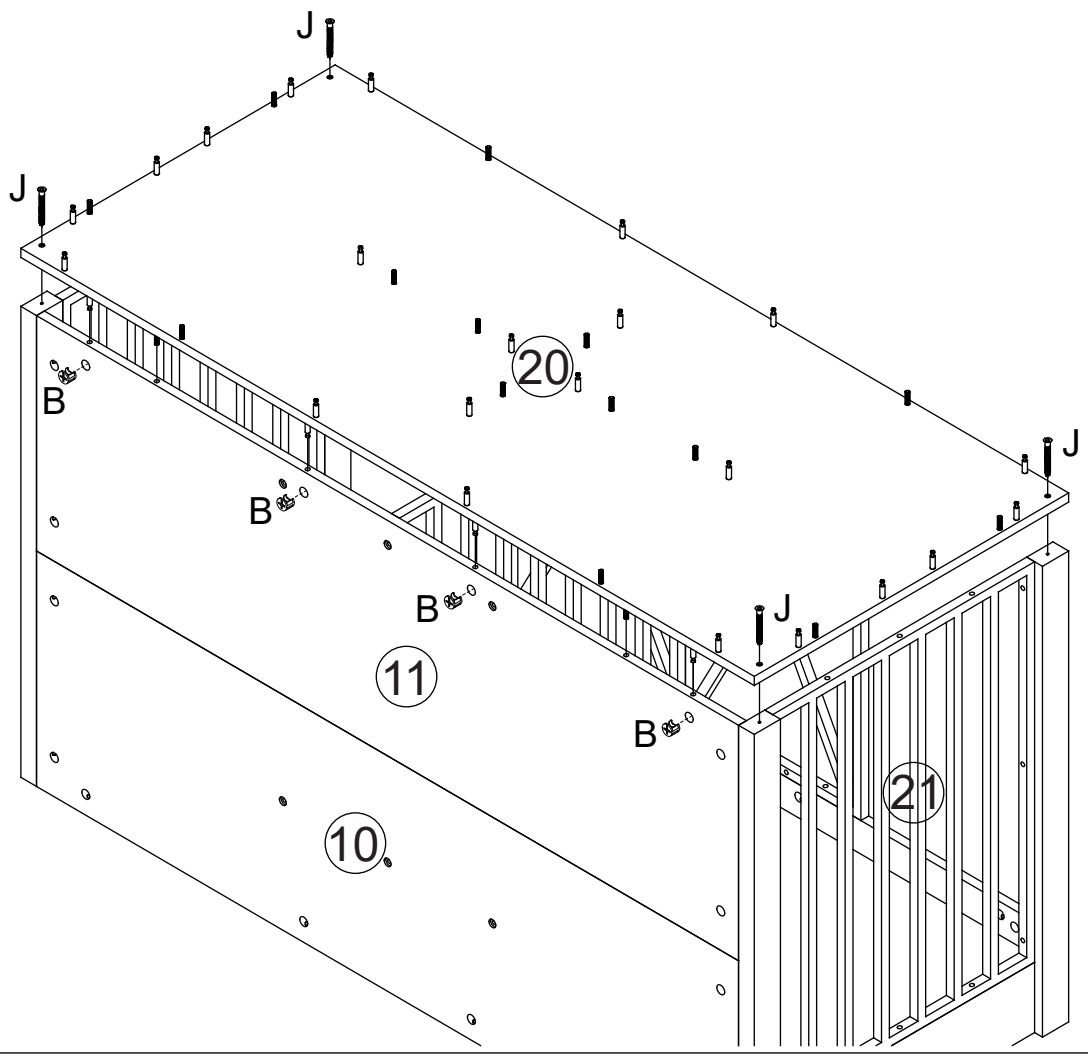
14



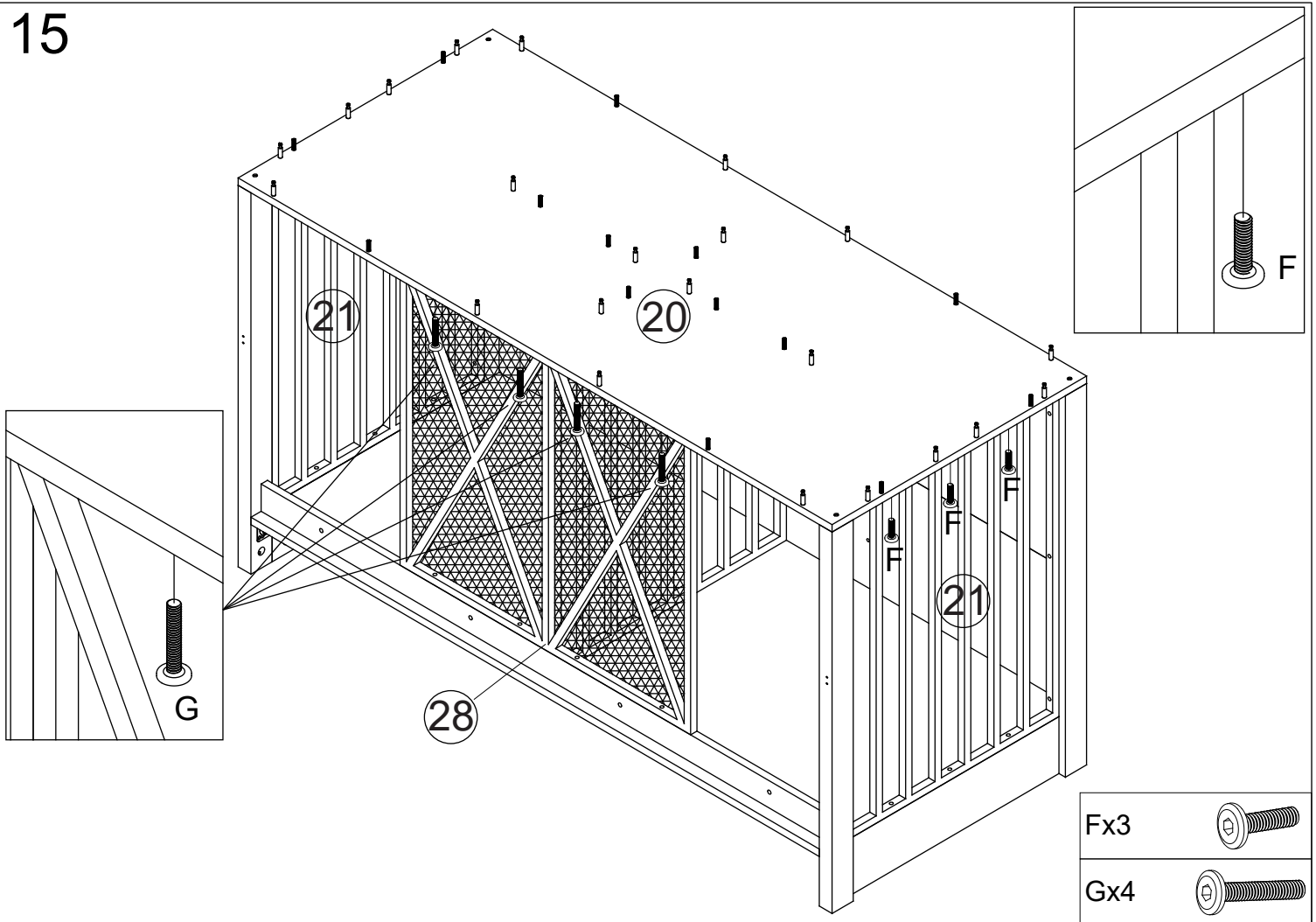

- Bx4 
- Jx4 

15



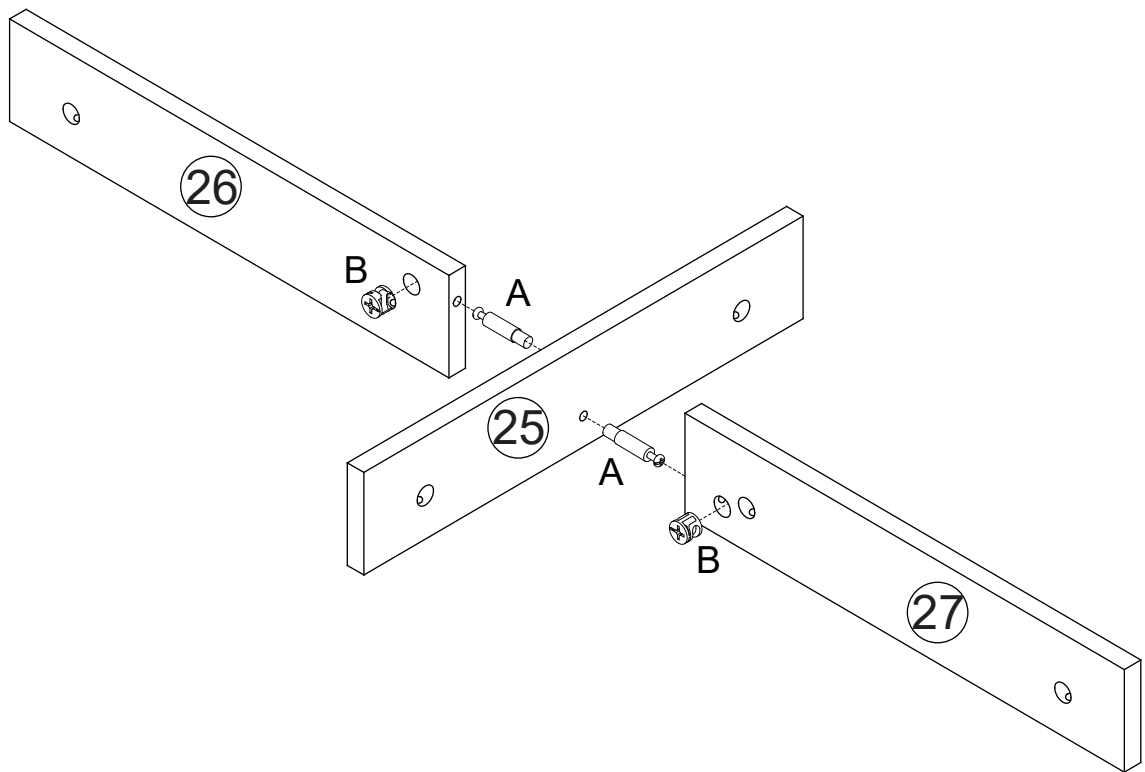

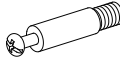
16



- | | |
|-----|---|
| Ax2 |  |
| Bx2 |  |

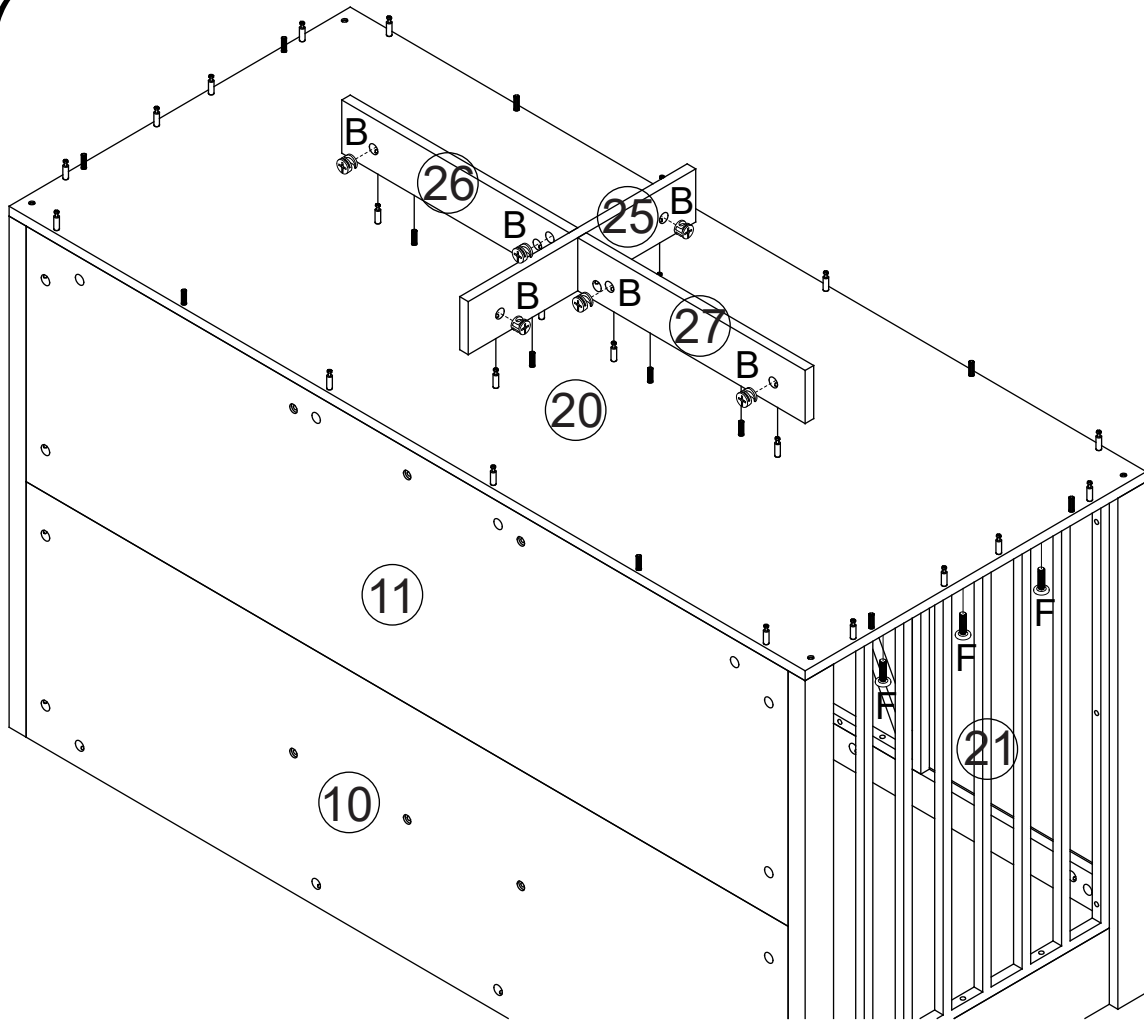

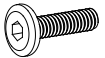
17

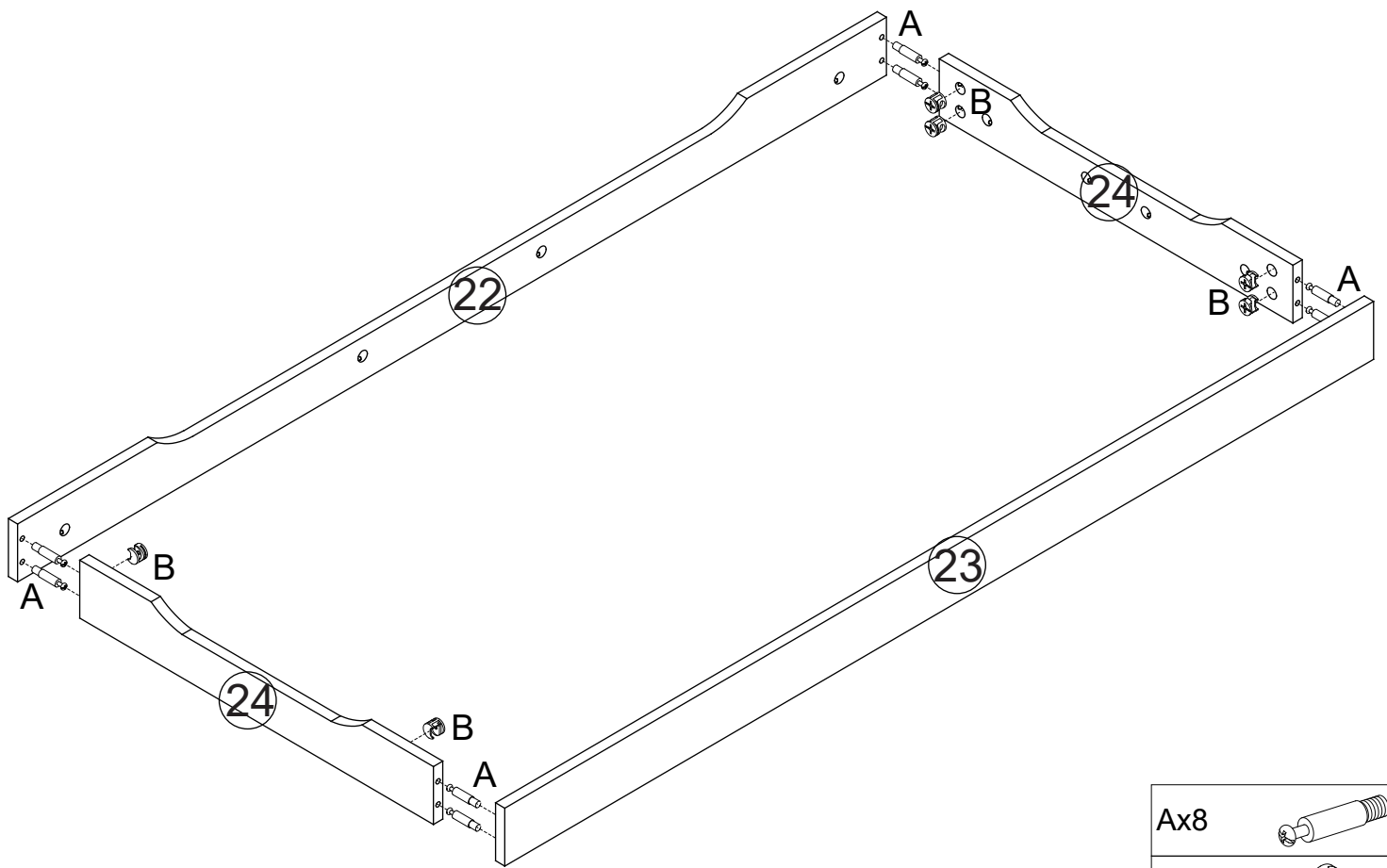

Fx3	
Bx6	

18

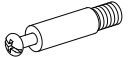

Ax8	
Bx8	

19

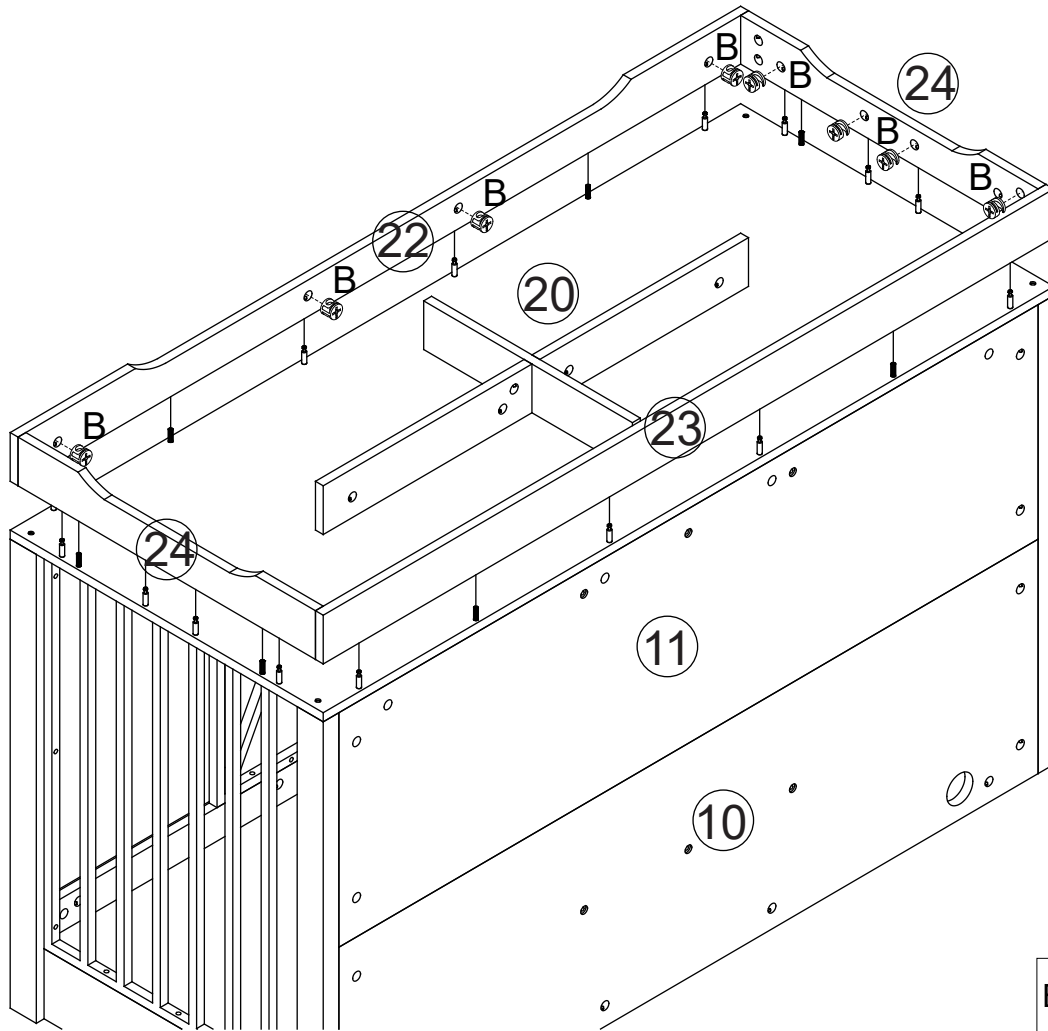

Bx16



20

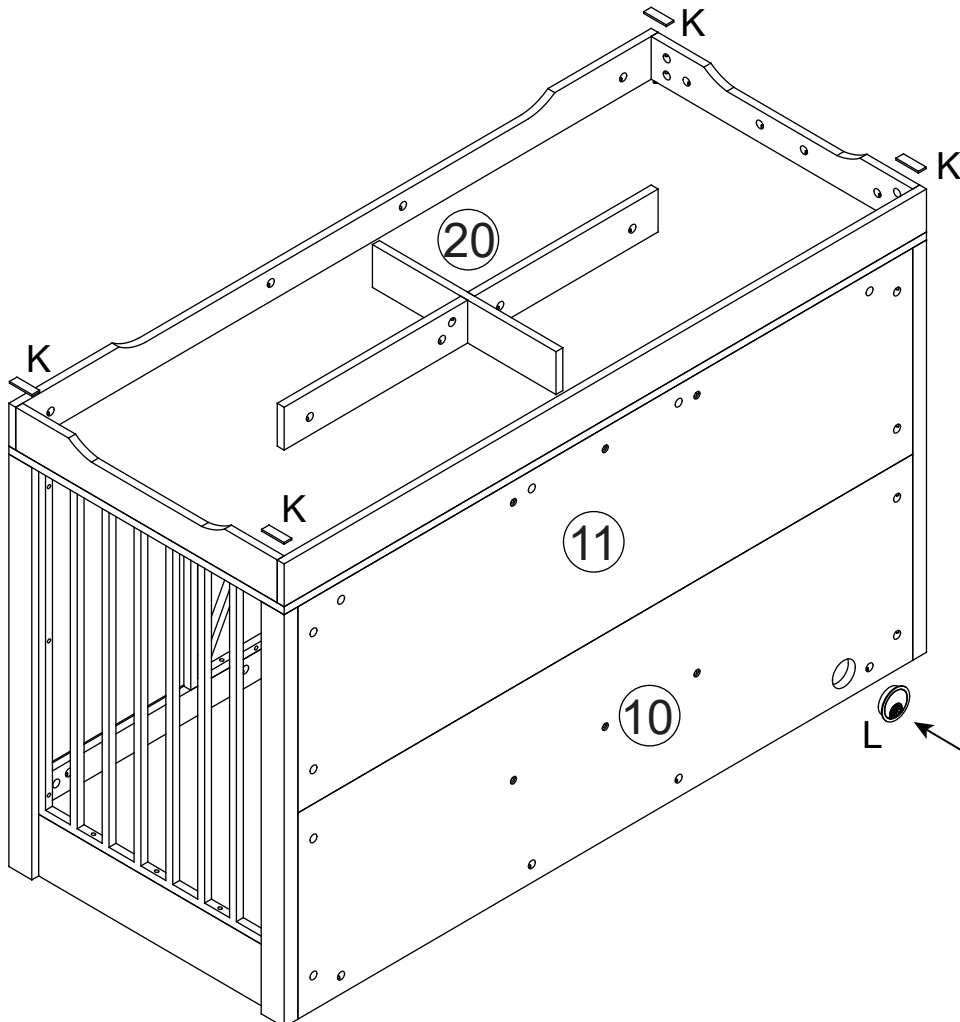

Kx4

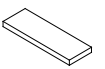

Lx1



21

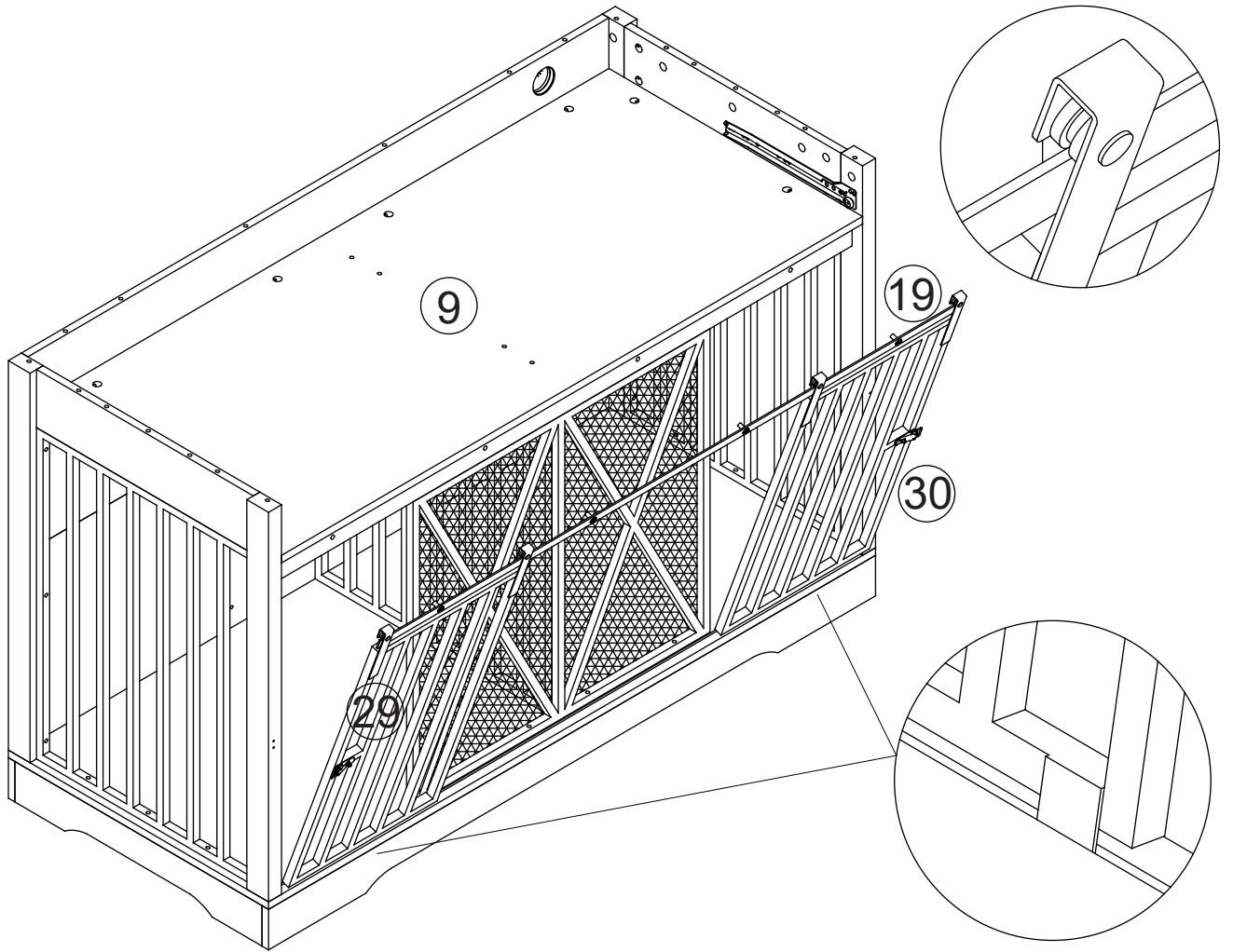

22

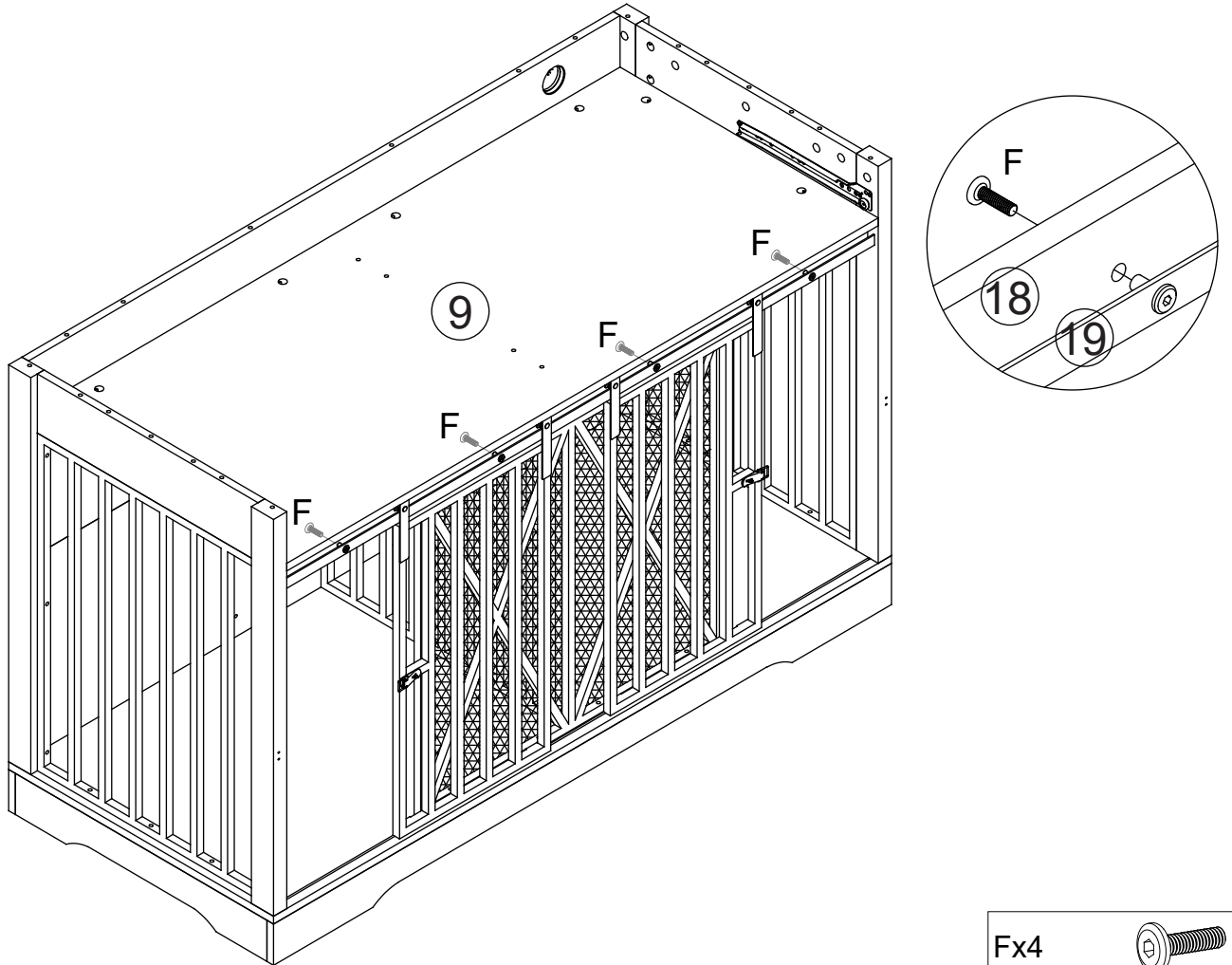

Fx4

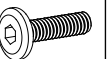

23

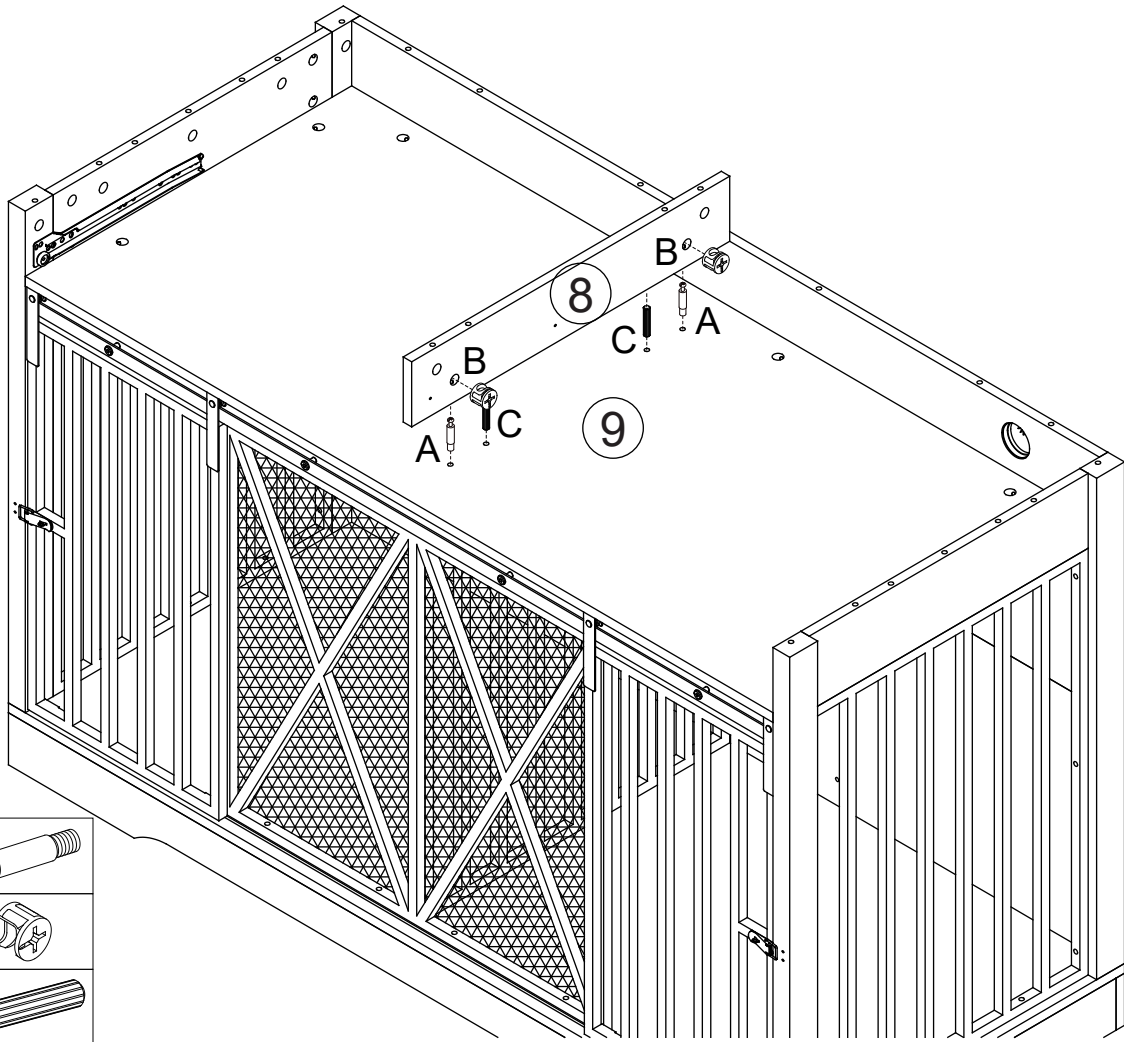

Ax2

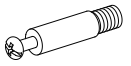

Bx2



Cx2

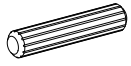

24

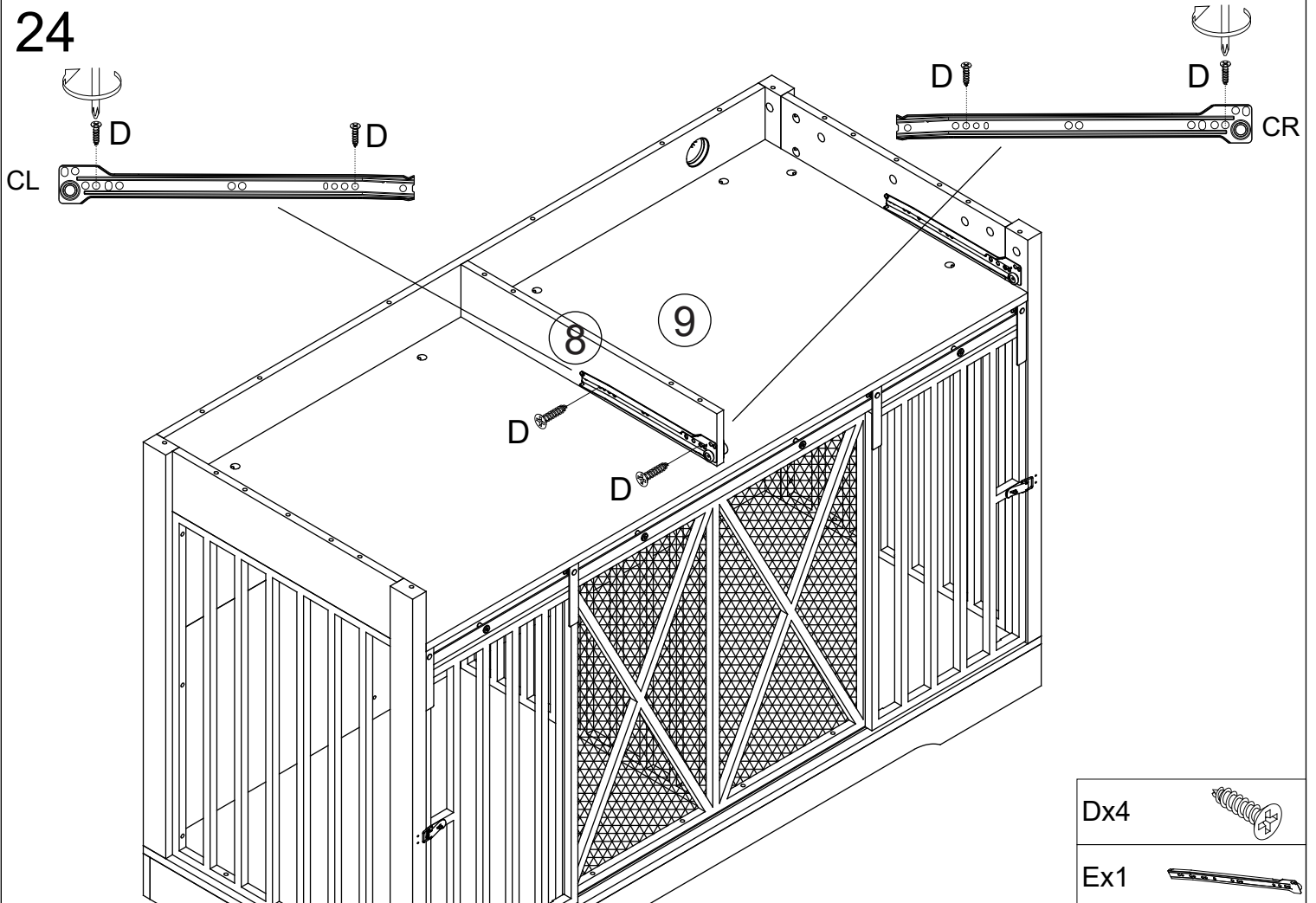

CL

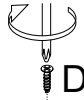

D

D

D

CR

Dx4

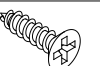



Ex1



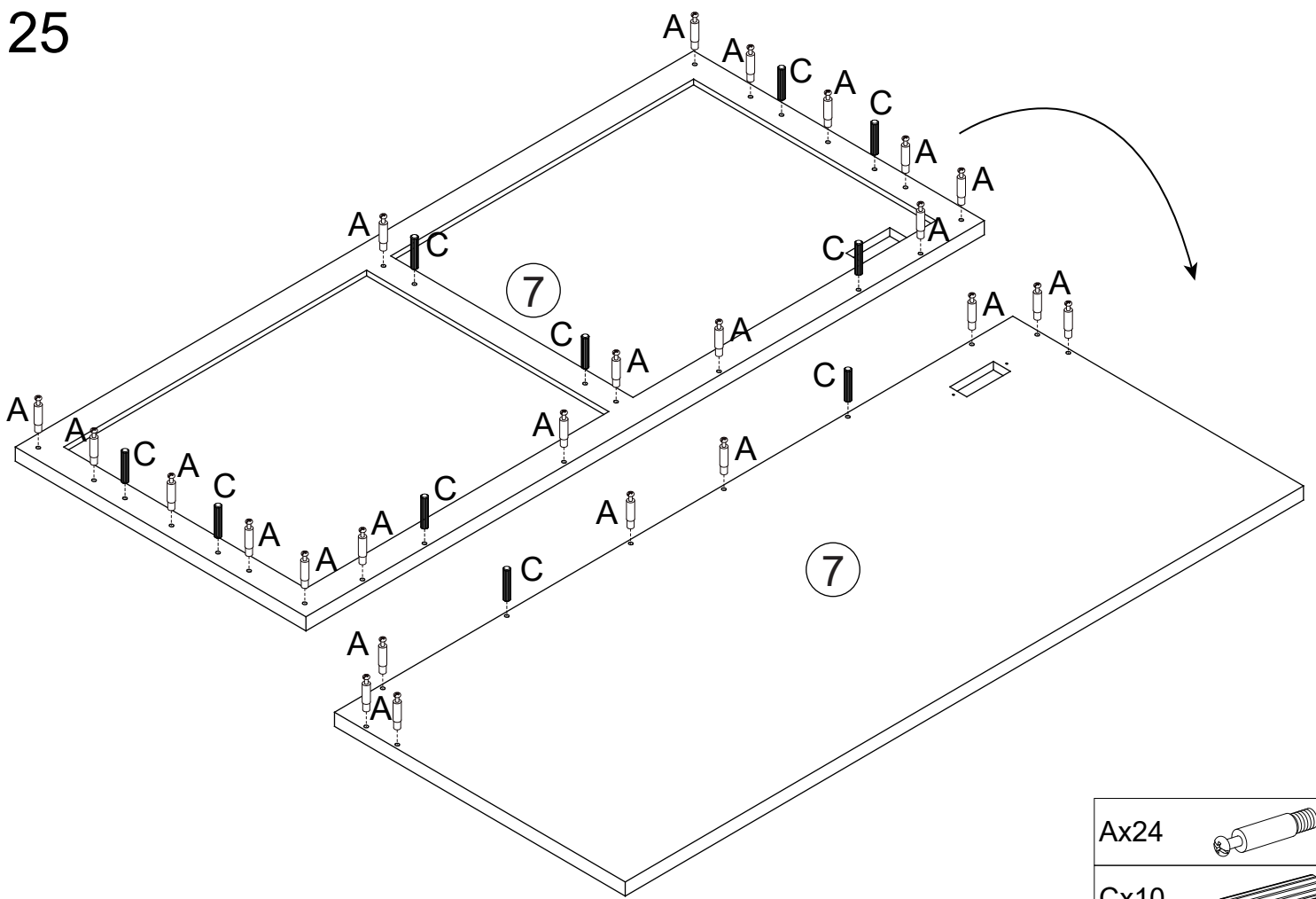

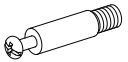
25

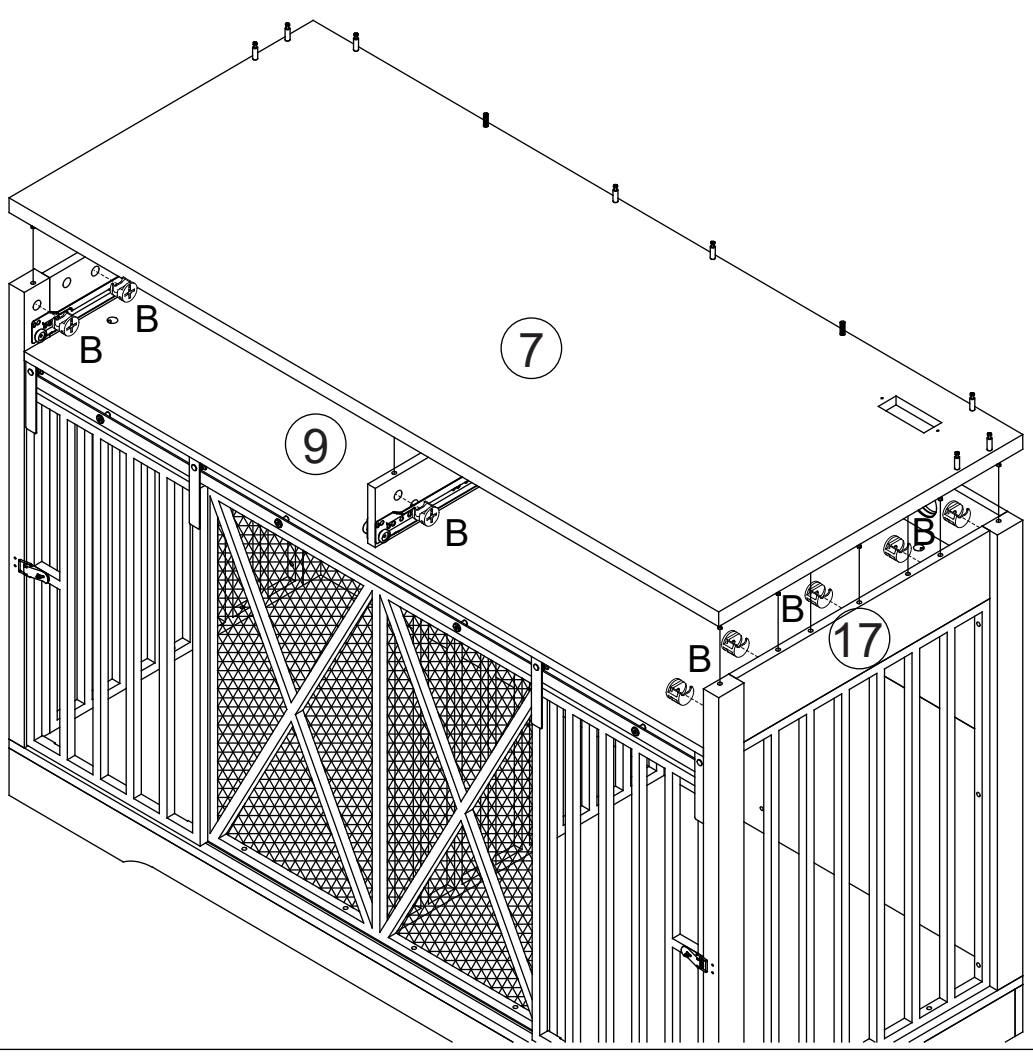

Ax24	
Cx10	

26



Bx16	
------	---

27

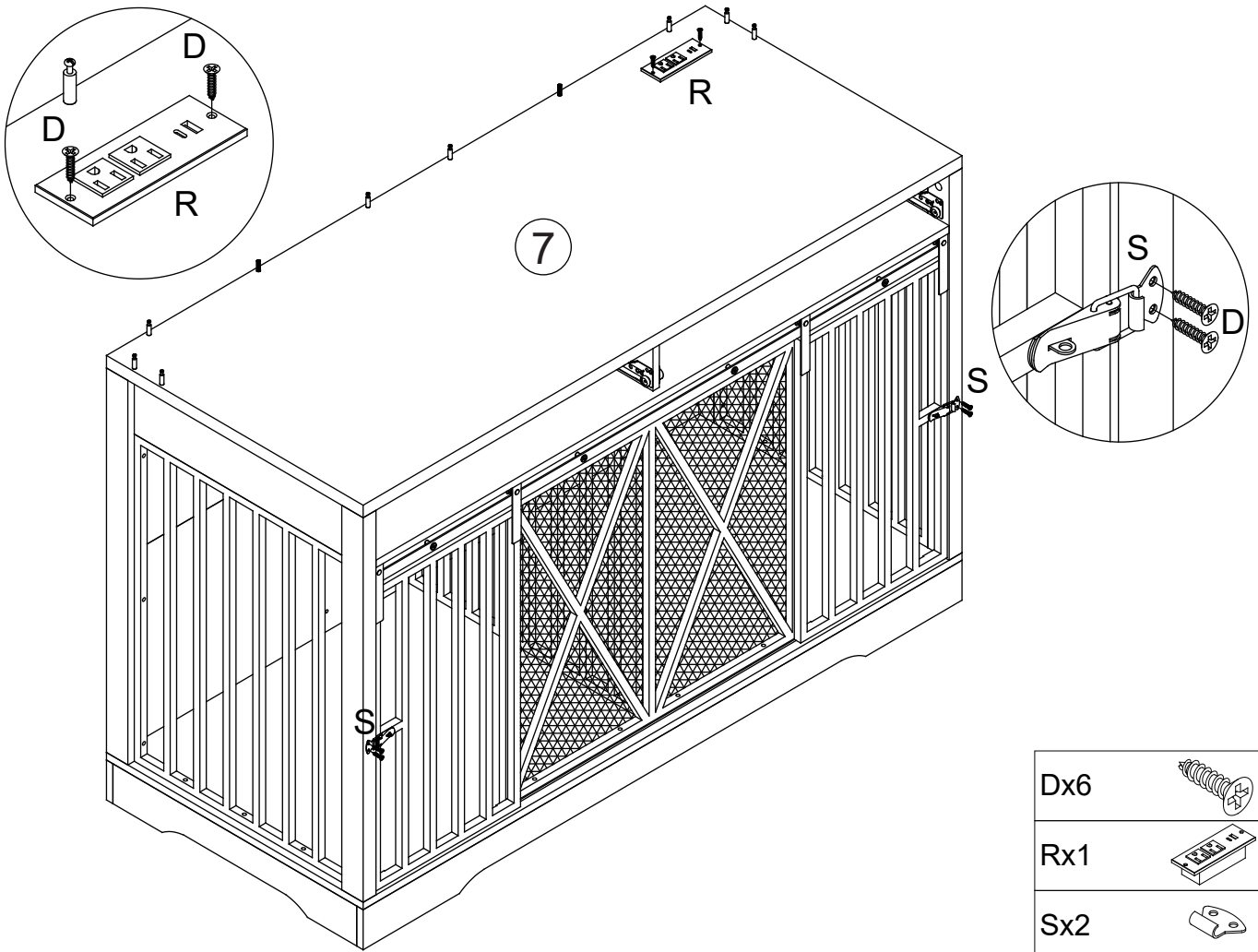

Dx6	
Rx1	
Sx2	

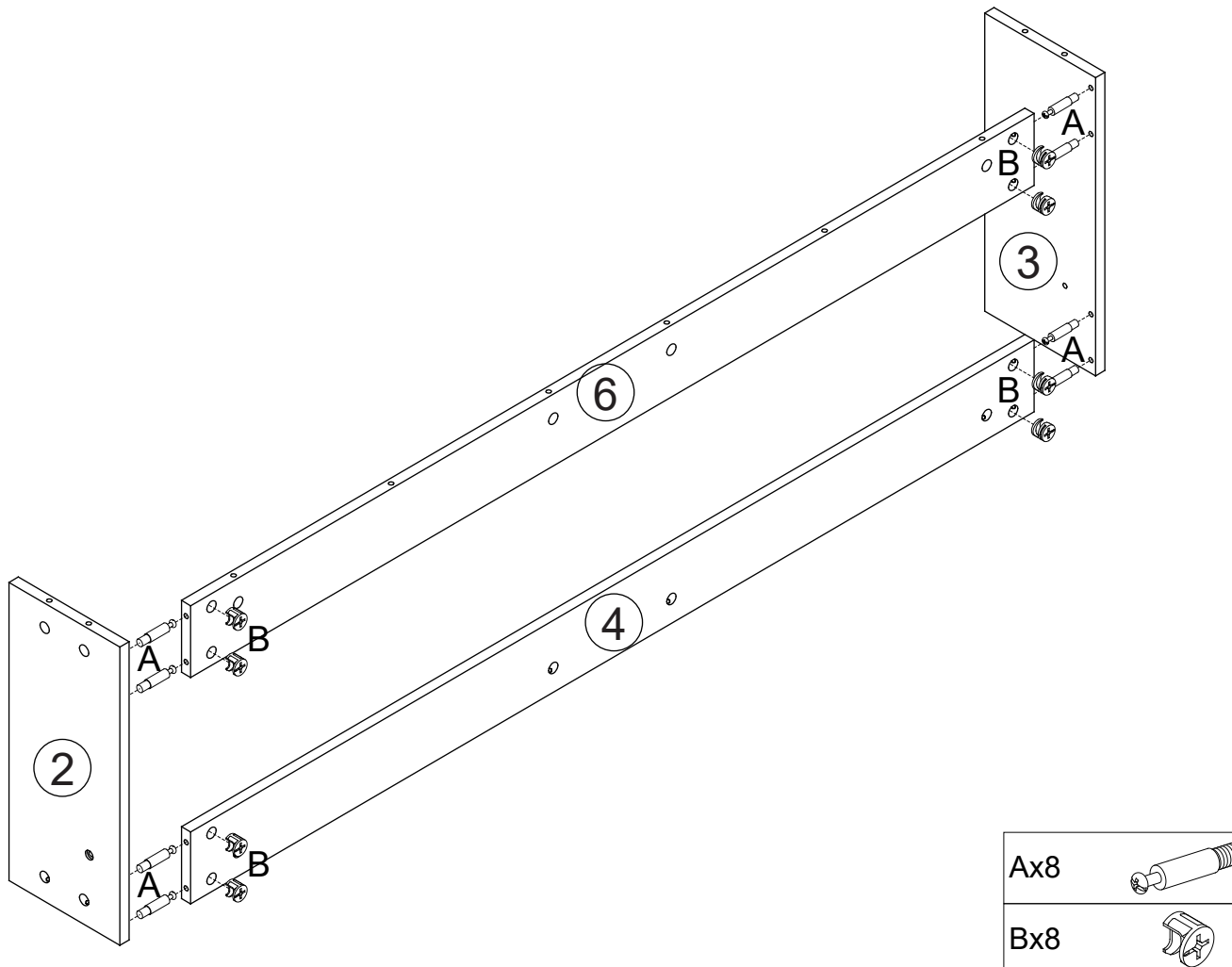

28

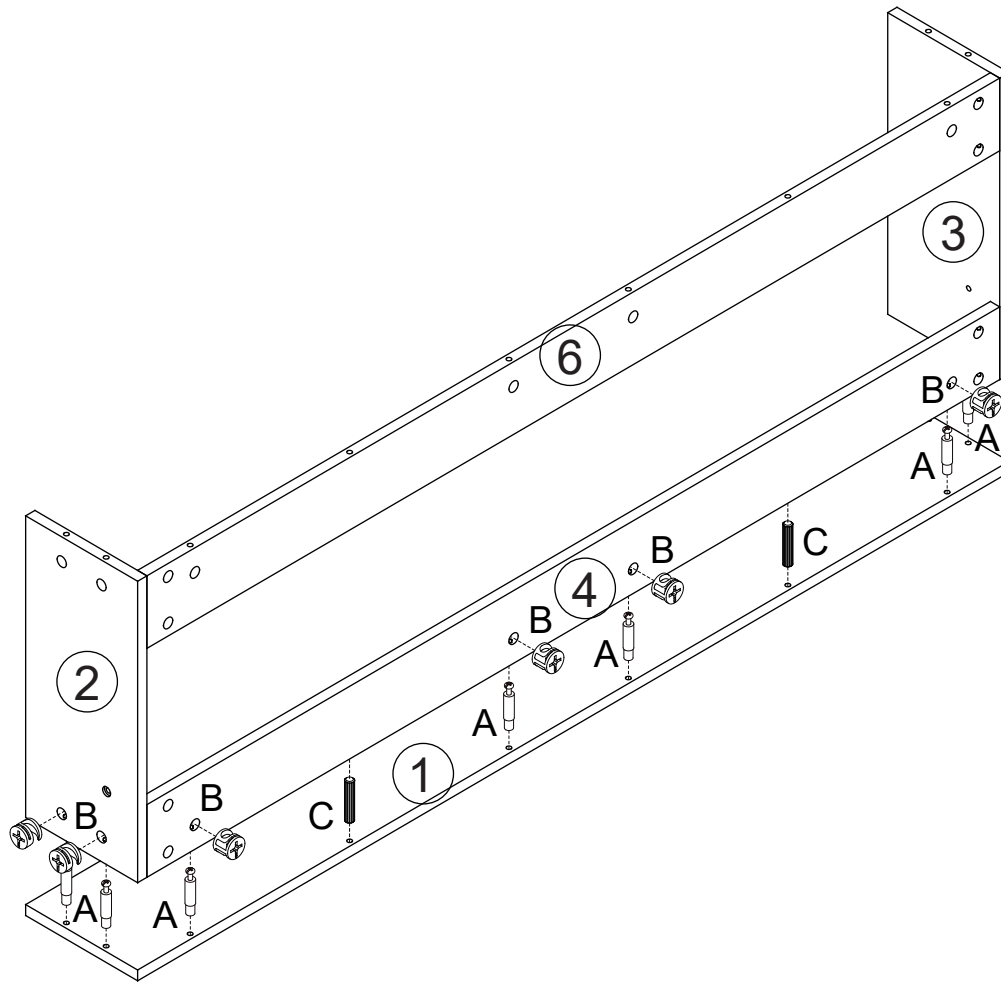

Ax8	
Bx8	

29

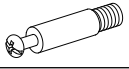

Ax8	
Bx8	
Cx2	

30

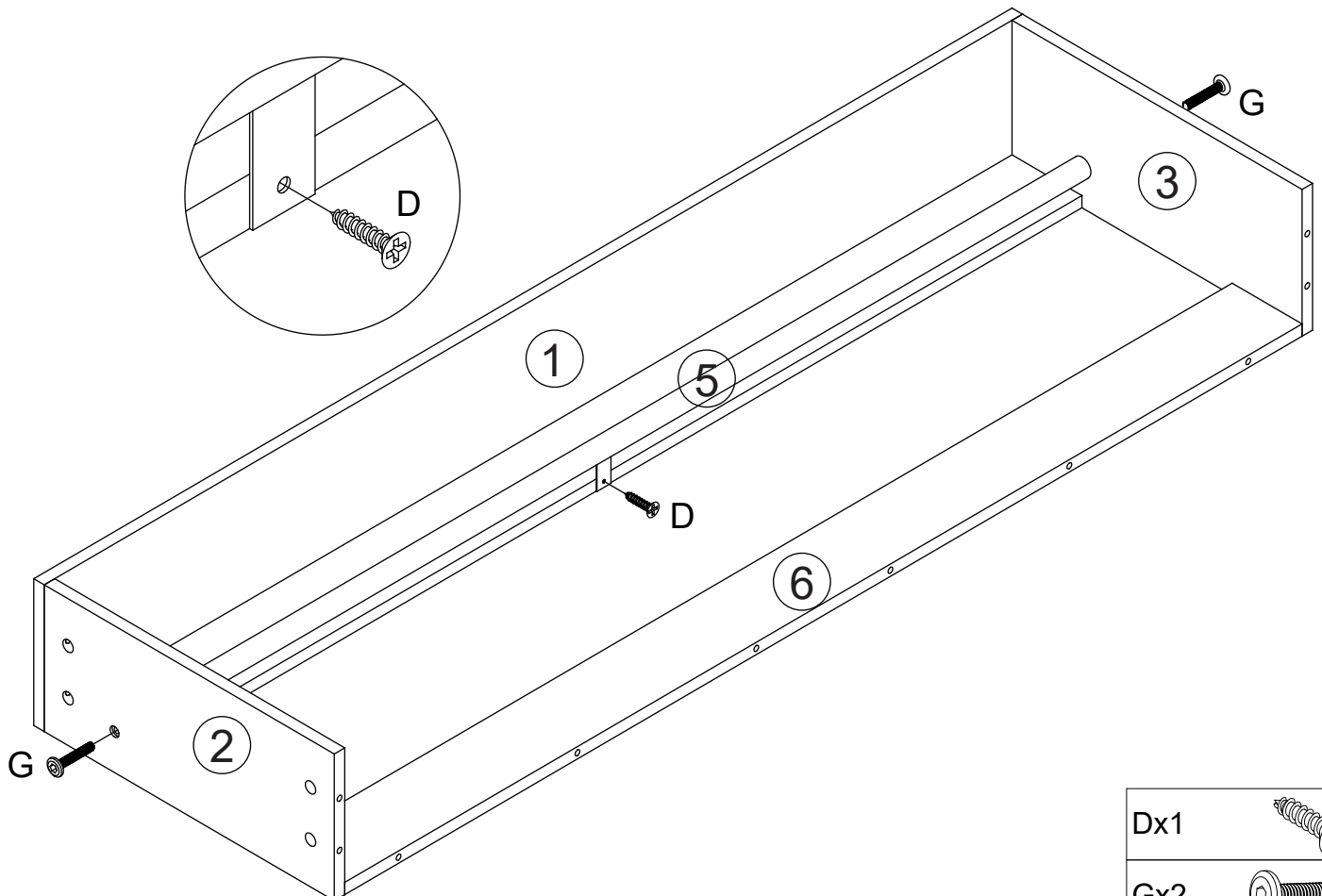

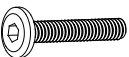
Dx1	
Gx2	

31

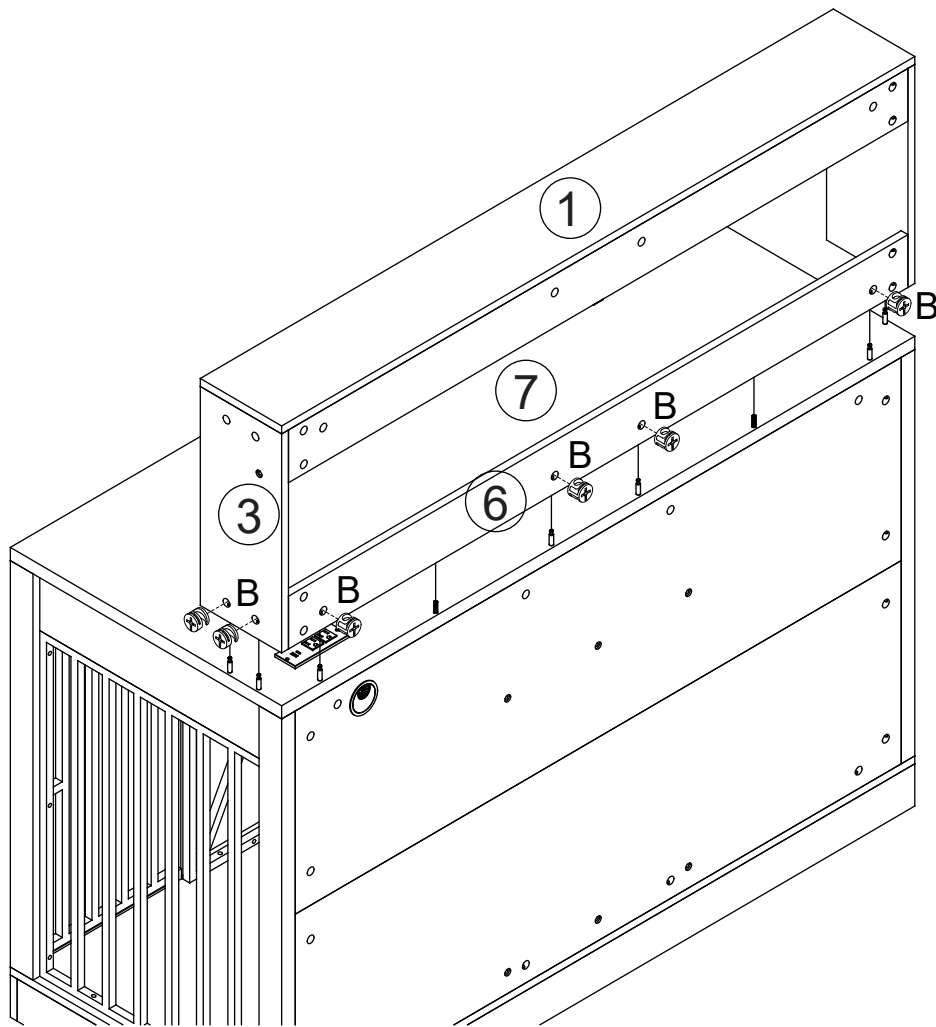

Bx8



32

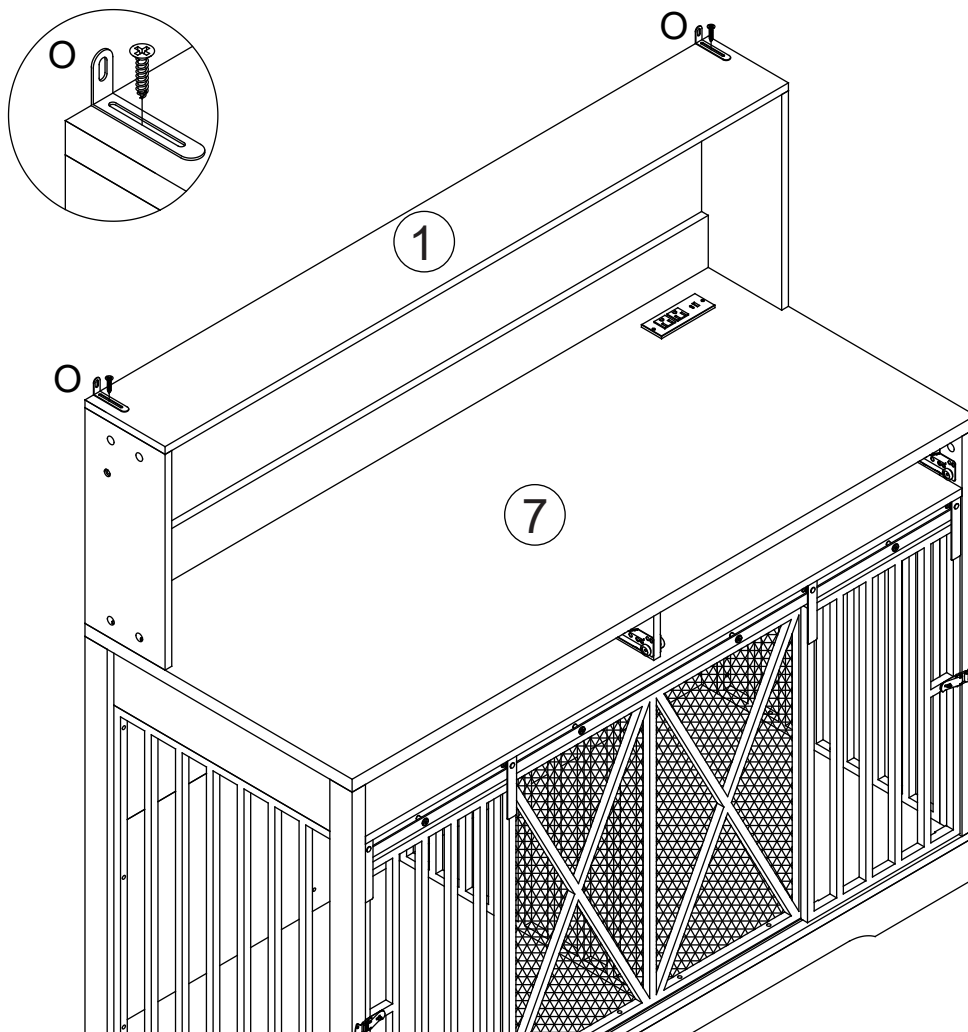

Ox2

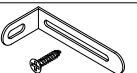

33

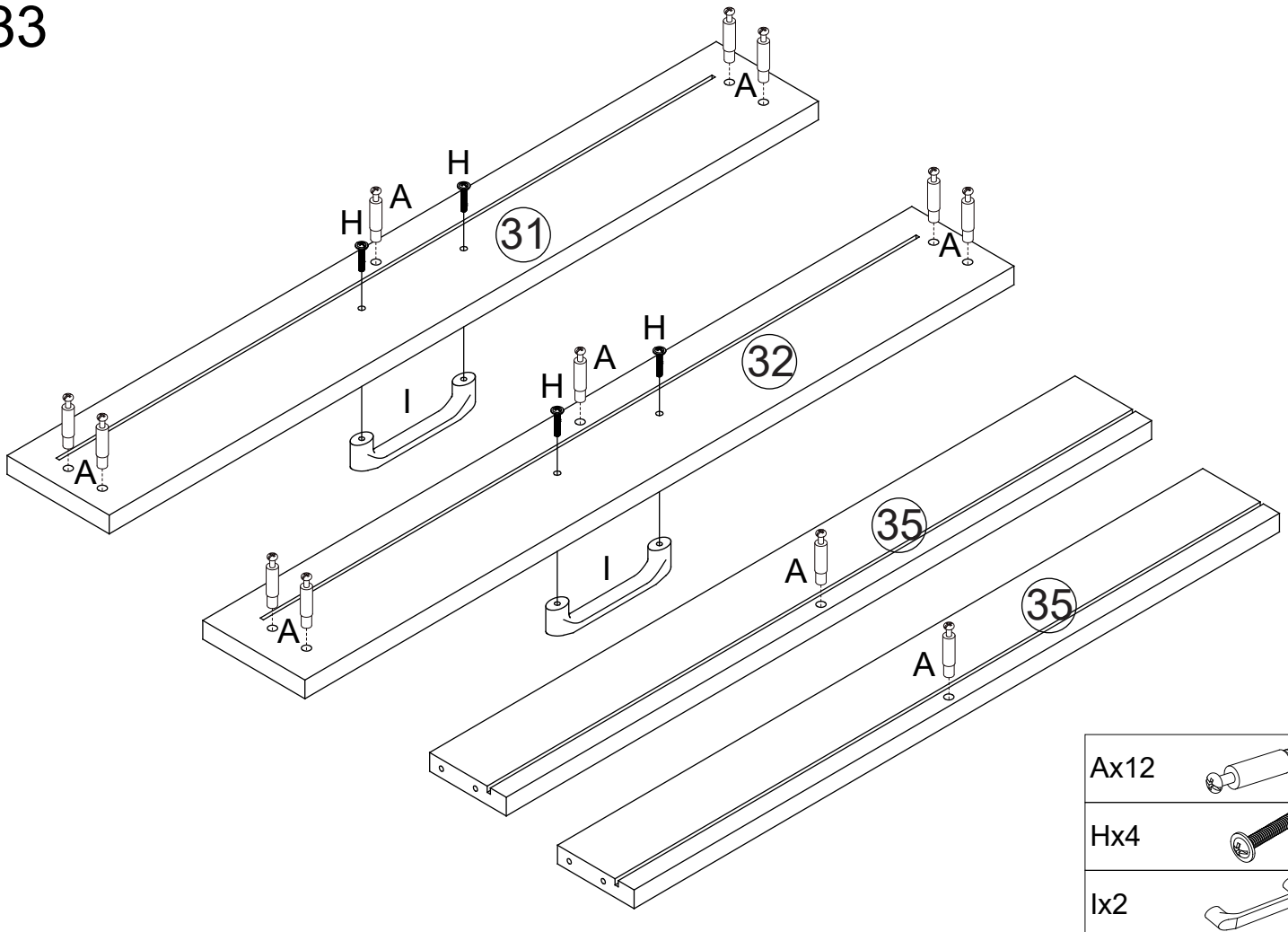

34

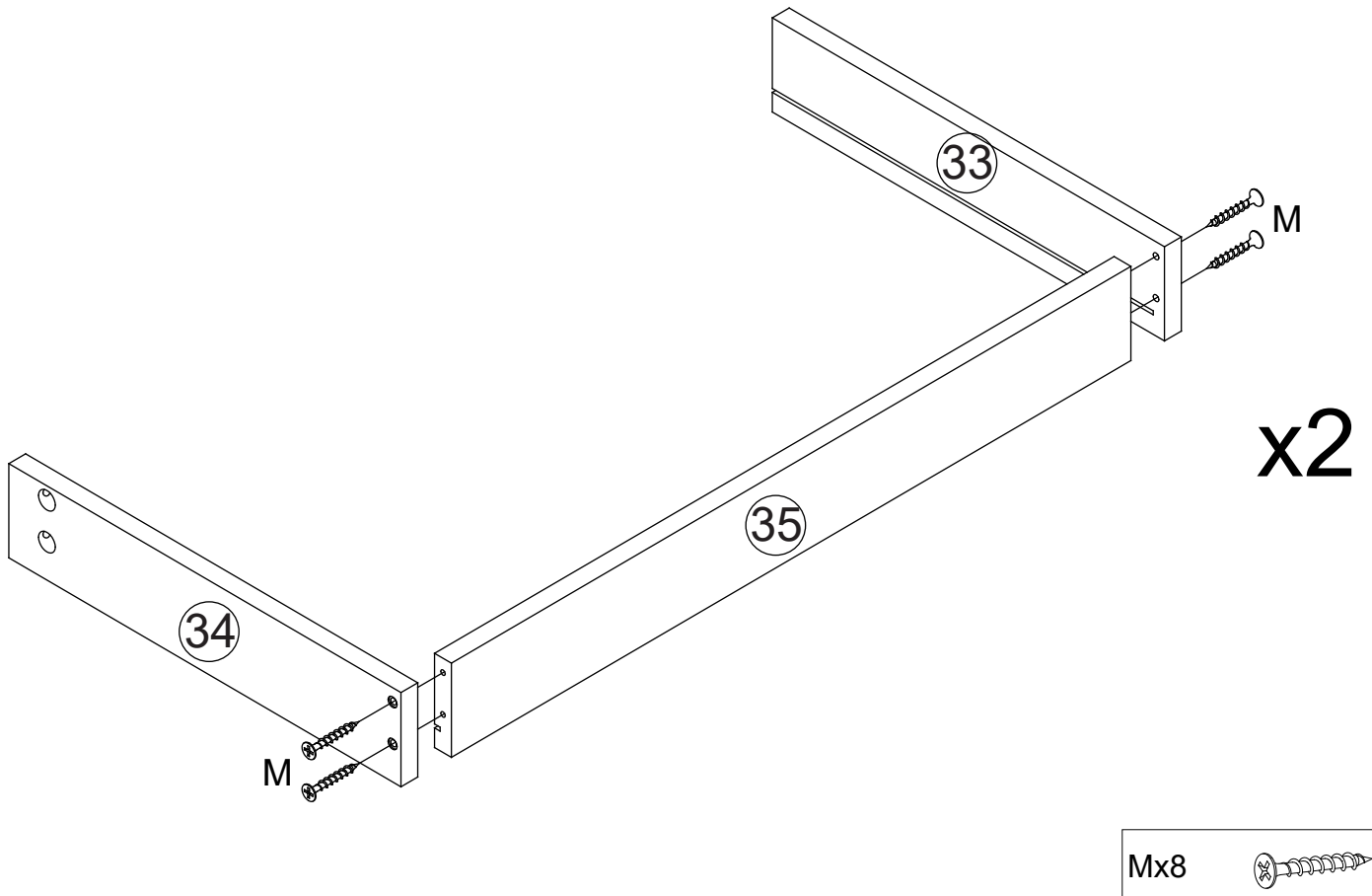

35

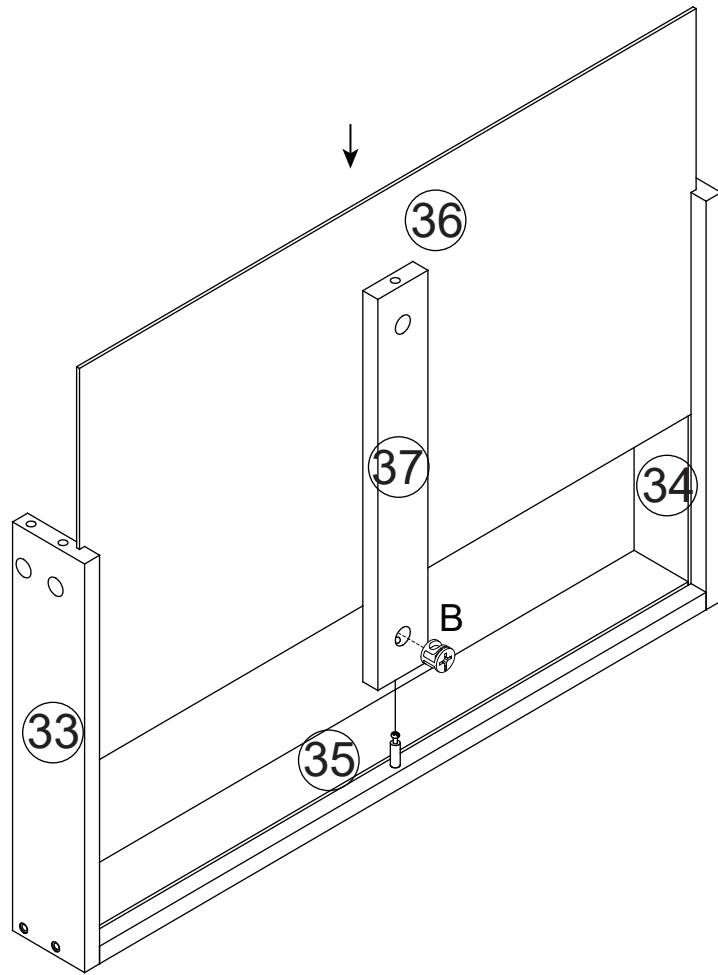

x2

Bx2



36

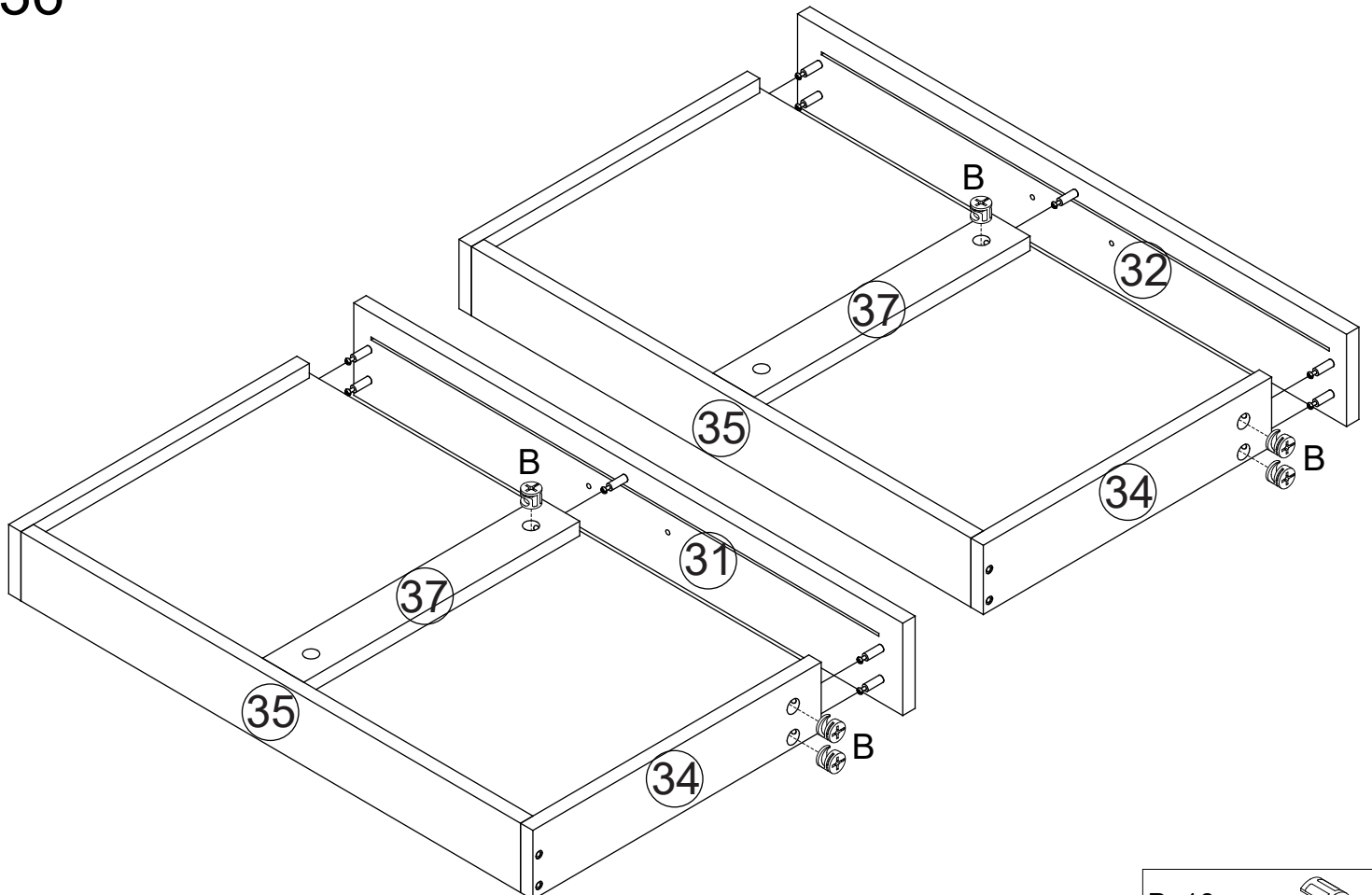

Bx10



37

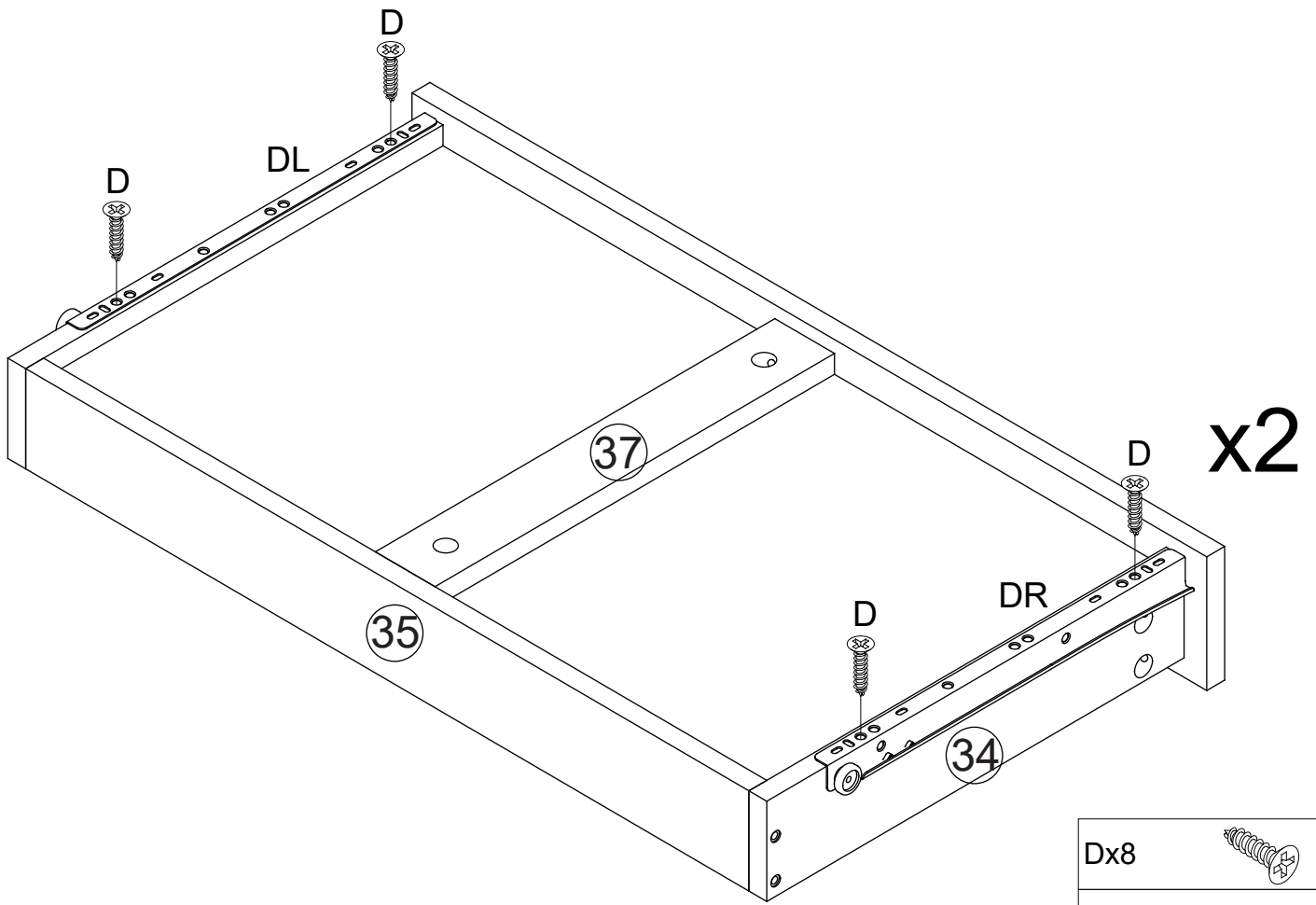

Dx8	
Ex2	

38

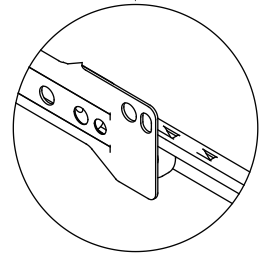
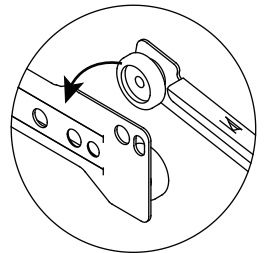
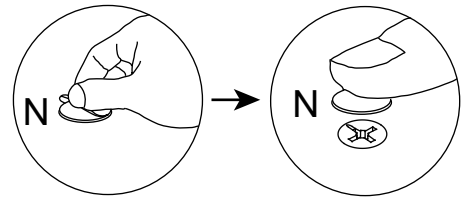
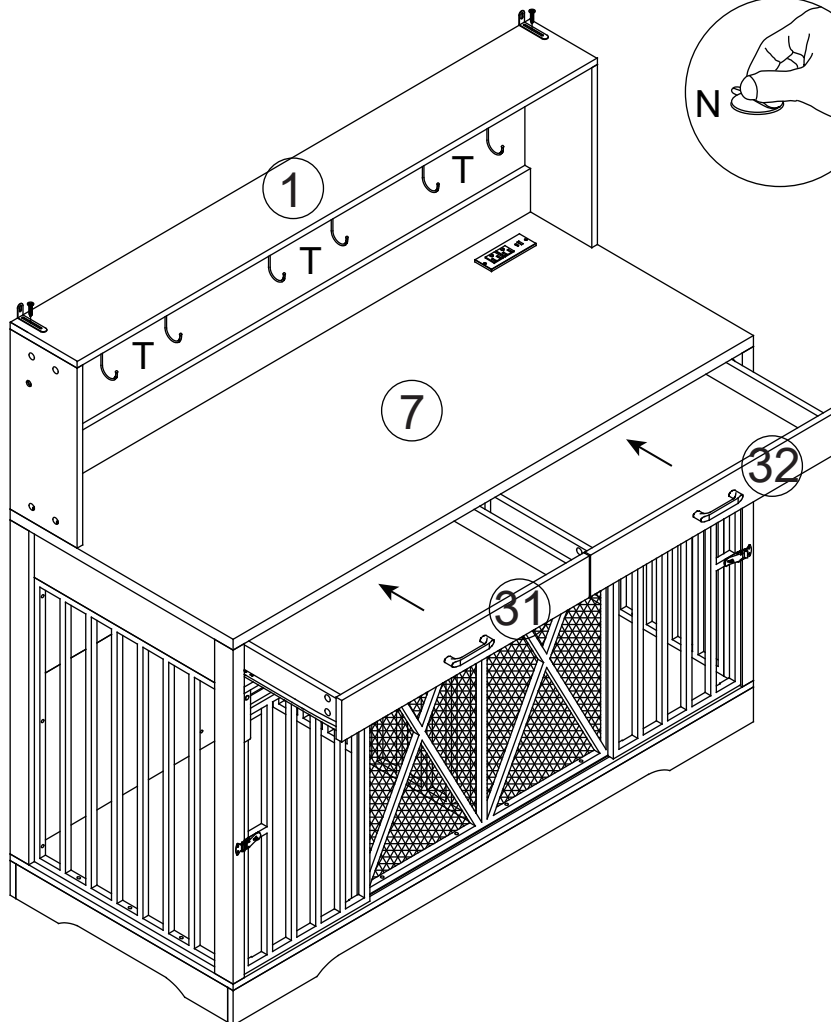
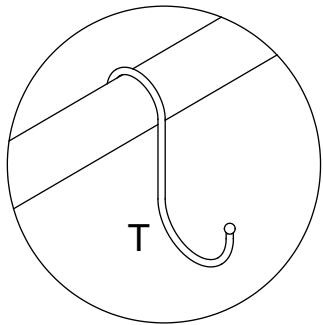

Tx6	
Nx120	

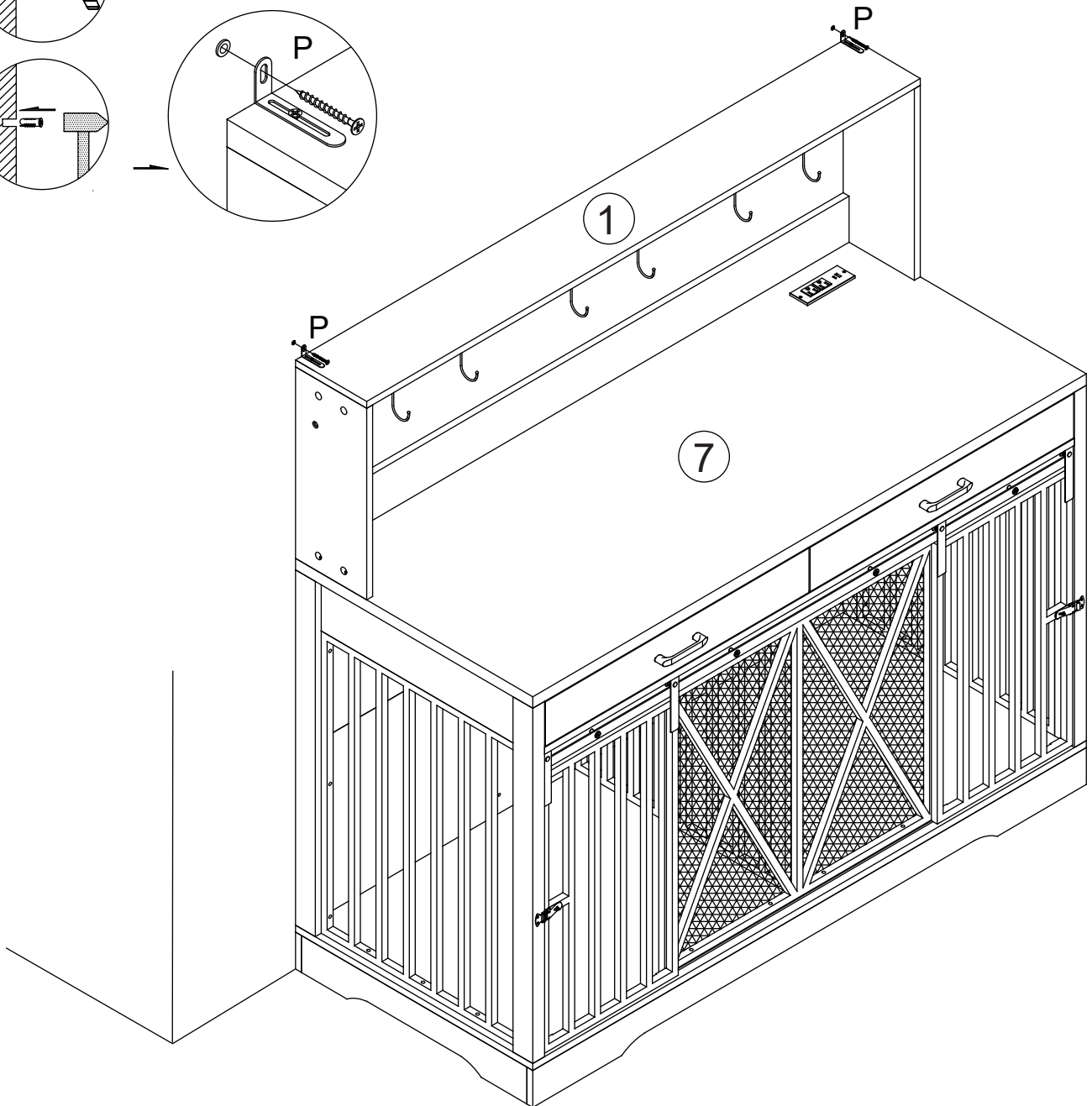
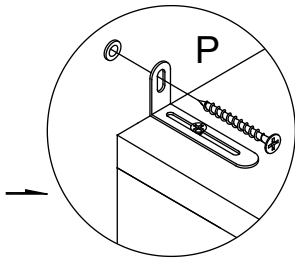
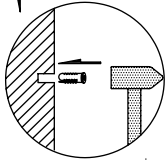
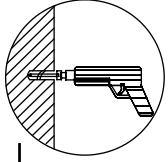

Px2

